

Installation Guidelines *50 Hz Air-Cooled Generator Sets*

8 kVA to 13 kVA

Original Instructions

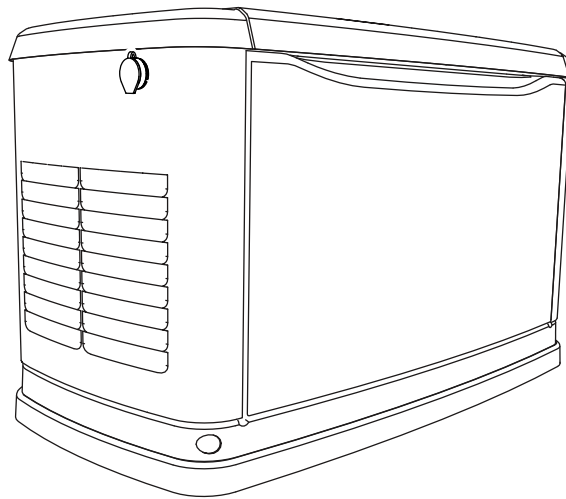

This product is not intended to be used in a critical life support application.

ISO000209b

Register your Pramac product at:
www.activategen.com

SAVE THIS MANUAL FOR FUTURE REFERENCE

Use this page to record important information about this generator set.

Model:	
Serial:	
Production Date:	
Volts:	
LPG Amps:	
NG Amps:	
Hz:	
Phase:	
Controller P/N:	
STA MAC ID:	
SSID:	

Record the information found on the unit data label on this page. See owner's manual for the location of the unit data label. The unit has a label plate affixed to the inside partition, to the left of the control panel console.

Always supply the complete model and serial numbers of the unit when contacting an Independent Authorized Service Dealer (IASD) about parts and service.

Operation and Maintenance: Correct maintenance and care of the generator set ensures a minimum number of problems and keeps operating expenses at a minimum. It is the operator's responsibility to perform all safety checks, to verify all maintenance for safe operation is performed promptly, and to have the equipment inspected periodically by an IASD. Normal maintenance, service, and replacement of parts are the responsibility of the owner/operator and are not considered defects in materials or workmanship within the terms of the warranty. Individual operating habits and usage may contribute to the need for additional maintenance or service.

When the generator set requires maintenance or service, Pramac recommends contacting an IASD for assistance. Authorized service technicians are factory-trained and are capable of handling maintenance and service needs. To locate the nearest IASD, see [Servicing Centers](#) at the end of this manual.

EC Declaration of Conformity

Manufacturer: **Generac Power Systems, Inc.**
S45 W29290 Hwy 59
Waukesha, WI 53189 USA

Generac Power Systems, Inc. hereby declares that the machinery described below fulfils all the relevant provisions of the Machinery Directive 2006/42/EC. The Machinery also conforms to the relevant provisions of Outdoor Noise Directive 2000/14/EC (as amended by Directive 2005/88/EC) Notified body: SNCH, 2a, Kalchesbruck L – 1852 Luxembourg and the Electromagnetic Compatibility Directive 2014/30/EU.

Machinery Description: **Generator Set**
Model Number: **Generac Model Numbers; G007144#, G007244#, G007145#, G007245#, G007146# and G007246# (“#” – 0 to 9 for minor design changes)**

The following standards have been complied with in part or in full as relevant:

Machinery Directive 2006/42/EC Harmonised Standards applied:

EN ISO 8528-13:2016 - Reciprocating internal combustion engine driven alternating current generating sets
IEC 60204-1:2010/AC:2010 - Electrical equipment of machines - Part 1: General requirements
ISO 12100:2010 - General principles for design - Risk Assessment and risk reduction, includes EN 14121:2007

Additional standards that have either been referred to or been complied with in part or in full as relevant:

ISO 8528-1:2005 - Reciprocating internal combustion engine driven alternating current generating sets
ISO 8528-5:2013 - Reciprocating internal combustion engine driven alternating current generating sets
IEC 60034-1:2010 - Rotating electrical machines – Part 1: Rating and performance

Harmonised Standards applied for Outdoor Noise Emission Directive 2000/14/EC:

ISO 8528-10:1998 – Reciprocating internal combustion engine driven alternating current generating sets
EN ISO 3744:2010 - Determination of sound power levels and sound energy levels of noise sources using sound pressure
Model number G007144# & G007244#: measured sound power level 94.0 dB(A), guaranteed sound power level 95 dB(A)
Model number G007145# & G007245#: measured sound power level 94.2 dB(A), guaranteed sound power level 95 dB(A)
Model number G007146# & G007246#: measured sound power level 94.8 dB(A), guaranteed sound power level 96 dB(A)

Harmonised Standards applied for Electromagnetic Compatibility Directive 2014/30/EU:

EN 55012:2007+A1:2009 – Vehicles, boats and internal combustion engines – Radio disturbance characteristics
EN 55014-1:2006 – Electromagnetic Compatibility – Requirements for household appliances, electric tools and similar apparatus. Part 1 - Emission
EN 55014-2:2015 – Electromagnetic compatibility – Requirements for household appliances, electric tools and similar apparatus. Part 2 - Immunity
EN 61000-3-2:2014 - Electromagnetic compatibility – Part 3-2: Limits – Limits for harmonic current emissions
EN 61000-3-3:2013 - Electromagnetic compatibility – Part 3-3: Limits – Limitation of voltage changes, voltage fluctuations and flicker in public low-voltage supply systems.

A Technical file has been compiled in accordance with Part A of Annex VII of Machinery Directive 2006/42/EC and is available to the European National authorities upon request.

Jeffrey Jonas
Staff Engineer-Certifications
Generac Power Systems, Inc.
S45 W29290 Hwy 59
Waukesha, Wisconsin, USA

Signature:



This document was made at Generac Power Systems, Inc. at the address noted above on February 15, 2018

Original document - written in English.



EU DECLARATION OF CONFORMITY (20560DOC00058A-rev.4)

- 1 **GS2101MIP, GS2101MIE** (product name)
- 2 GainSpan Corporation, 3590, N 1st St, #300, San Jose, CA 95134, USA (manufacturer)
- 3 This declaration of conformity is issued under the sole responsibility of the manufacturer
- 4 IEEE 802.11 b/g/n Wi-Fi module with software versions 5.2.3, 5.2.4, 5.2.5, 5.3.0, 5.4.0, 5.5.0.



Operating RF frequency range: 2400MHz to 2483.5MHz
 Max radio frequency power transmitted:
 GS2101MIP: 15.49 dBm (802.11b)
 GS2101MIE: 18.59 dBm (802.11b)

- 5 The object of the declaration described above is in conformity with the relevant Community harmonisation: European Directive 2014/53/EU (RED)
- 6 The conformity with the essential requirements set out in Art.3 of the 2014/53/EU has been demonstrated against the following harmonized standards:

Harmonized Standard reference	Article of Directive 2014/53/EU
EN 60950-1: 2006 + A2: 2013 EN 62311:2008	3.1 (a): Health and Safety of the User
EN 301 480-1 V2.2.0 (2017-03), EN 301 489-17 V3.2.0 (2017-03)	3.1 (b): Electromagnetic Compatibility
EN 300 328 V2.1.1 (2016-11)	3.2: Effective use of spectrum allocated

- 7 The conformity assessment procedure referred to in Article 17 and detailed in Annex III of Directive 2014/53/EU has been followed with the involvement of the following Notified Body:

Bay Area Compliance Laboratories Corp, 1274 Anvilwood Ave, Sunnyvale, CA 94089, USA

Thus,  is placed on the product

- 8 The product can be considered compliant to the essential requirements set out in Art.3 of 2014/53/EU only in combination with the above-mentioned SW version(s).
- 9 The Technical Documentation (TD) relevant to the product described above and which supports this Declaration of Conformity, is held at: GainSpan Corporation, 3590, N 1st St, #300, San Jose, CA 95134, USA

Trieste, **2017-11-30**

 Global CFO
 Eran Edri

EU-Type Examination Certificate No: **R1705305**

Technical Documentation: **30560TCF00080A**

www.Telit.com/RED

Telit Communications S.p.A.
 Via Stazione di Prosecco n. 5/B
 34010 Sgonico (TS) - ITALY
 Phone +39 040 4192 111
 Fax +39 040 4192 333

Cap. Soc. € 3.000.000
 Partita IVA 03711600266
 Cod.Fisc. 03711600266
 Nr. R.E.A. TS-120027

Società soggetta all'attività
 di direzione e coordinamento
 da parte di Telit Communications PLC
 con sede in Londra (art.2497 bis C.C.)

Società con socio unico
 (Telit Communications PLC)

Table of Contents

Section 1: Safety Information

Introduction	1
Read This Manual Thoroughly	1
Safety Messages	1
Safety and Informational Decals	2
Safety Rules	5
General Safety	5
Installation	6
Operation	7
Maintenance	7
Hot Surfaces	9
Before You Begin	10
Standards Index	10

Section 2: Unpacking and Inspection

General	11
Required Tools	11
Unpacking	11
Opening The Lid	12
Enclosure Panel Removal	12
Front Access Panel Removal	12
Intake Side Panel Removal	13
Customer Connections and Loose Parts	13
Rear Connections	13
Generator Main Line Circuit Breaker	14
Parts Shipped Loose	14

Section 3: Site Selection and Preparation

Site Selection	15
Carbon Monoxide	15
Carbon Monoxide Detectors	15
Potential CO Entry Points	16
Protect the Structure	16
Fire Prevention	17
Distance Requirements	17
Fire Codes, Standards, and Guidelines	18
Generator Set Maintenance	18
Fresh Air for Ventilation and Cooling	19
Water Ingress Avoidance	19
Proximity to Utilities	19
Verify Wi-Fi Range	19

Transportation Recommendations	19
Suitable Mounting Surface	19
Placement on Roofs, Platforms, and Other Supporting Structures	19

Section 4: Generator Set Placement

Generator Set Weight (kg / lb)	21
Lifting Instructions	21
Generator Set Placement	21

Section 5: Fuel Conversion / Gas Connections

Fuel Requirements and Recommendations	23
BTU Content	23
Fuel Pressure	23
Fuel Conversion	23
Fuel Consumption	24
Fuel Line Sizing	24
Natural Gas Pipe Sizing	25
LP Gas Pipe Sizing	25
Installing and Connecting Fuel Lines	26
Fuel Shutoff Valve	26
Flexible Fuel Line	26
Sediment Trap	26
Checking Fuel Line Connections	27
Checking Fuel Pressure	27
Performing Fuel System Leak Test	27
Natural Gas Installation (Typical)	28
LP Gas (Vapor) Installation (Typical)	29

Section 6: Electrical Connections

Generator Set Connections	31
Control Wiring	32
Main AC Wiring	33
Common Alarm Relay (Option)	33
Battery Requirements	33
Battery Installation	33
Connecting Battery	34
Battery Disposal	35

Section 7: Control Panel Startup / Testing

Control Panel Interface37

Using the Control Panel Interface37

Control Panel Setup37

 Activation 37

 Cold Smart Start 39

 Setting The Exercise Timer 39

Before Initial Startup39

 Install Wizard 40

 Interconnect System Self Test Feature 40

 Before starting, complete the following: 40

Checking Manual Transfer Switch Operation43

Electrical Checks43

Generator Set Tests Under Load43

Checking Automatic Operation44

Installation Summary44

Shutting Generator Set Down While Under Load Or During A Mains Power (Utility) Outage44

Section 8: Troubleshooting

Generator Set Troubleshooting47

Section 9: Quick Reference Guide

Quick Reference Guide49

Section 10: Accessories

Section 11: Diagrams

Installation Drawing (10000010676—1 of 2) 53

Installation Drawing (10000010676—2 of 2) 54

Wiring Diagram (10000007481—1 of 6) 55

Wiring Diagram (10000007481—2 of 6) 56

Wiring Diagram (10000007481—3 of 6) 57

Wiring Diagram (10000007481—4 of 6) 58

Wiring Diagram (10000007481—5 of 6) 59

Wiring Diagram (10000007481—6 of 6) 60

Section 12: Servicing Centers

Section 1: Safety Information

Introduction

Thank you for purchasing this compact, high performance, air-cooled, engine-driven generator set. It is designed to automatically supply electrical power to operate critical loads during a mains (utility) power failure.

This unit is factory installed in an all-weather, metal enclosure intended exclusively for outdoor installation. This generator set will operate using either vapor withdrawn liquid propane (liquid propane gas [LPG]) or natural gas (NG). See *Fuel Requirements and Recommendations*.

NOTE: This generator set is intended to be used for supplying typical residential loads such as induction motors (sump pumps, refrigerators, air conditioners, furnaces, etc.), electronic components (computer, monitor, TV, etc.), lighting loads, and microwaves, when sized correctly.

This unit is also equipped with a Wi-Fi® module, which enables the owner to monitor generator set status from anywhere they have Internet access.

NOTE: Wi-Fi® is a registered trademark of Wi-Fi Alliance®.

The information in this manual is accurate based on products produced at the time of publication. The manufacturer reserves the right to make technical updates, corrections, and product revisions at any time without notice.

Read This Manual Thoroughly



Read instruction manual.
Read and understand manual completely before using this equipment.

ISO000100a

If any section of this manual is not understood, contact the nearest Independent Authorized Service Dealer (IASD) for starting, operating, and servicing procedures. The owner is responsible for correct maintenance and safe use of the unit.

This manual must be used in conjunction with all other supporting product documentation supplied with the product.

SAVE THESE INSTRUCTIONS for future reference. This manual contains important instructions that must be followed during placement, operation, and maintenance of the unit and its components. Always supply this manual to any individual that will use this unit, and instruct them on how to correctly start, operate, and stop the unit in case of emergency.

Safety Messages





Throughout this publication and on tags and decals affixed to the generator set, three types of safety messages are used to alert personnel to special instructions about a particular operation which may be hazardous if performed incorrectly or carelessly. Observe them carefully. Their definitions are as follows:



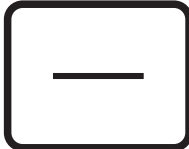
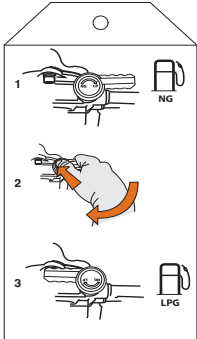
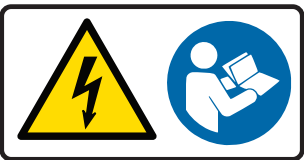

	<p>HAZARD WARNING Yellow triangle with black border and black symbol; indicates a hazardous situation which, if not avoided, could result in death or serious injury.</p>
	<p>MANDATORY ACTION Blue circle with white symbol; indicates an action required to safeguard personal health and / or avoid causing a hazardous situation which could result in death or serious injury.</p>
	<p>PROHIBITION Red ring with diagonal bar and black symbol; indicates a prohibited action. Performing the prohibited action may cause a hazardous situation which could result in death or serious injury.</p>
<p>—</p>	<p>NOTE Notes provide additional information important to a procedure or component.</p>

These safety messages cannot eliminate the hazards they indicate. Observing safety precautions and strict compliance with the special instructions while performing the action or service are essential to preventing accidents.

Safety and Informational Decals

This unit is equipped with safety and informational decals displaying pictorial symbols. These symbols and decals are described below. Locations are identified in *Figure 1-1*. Contact an IASD for a replacement if a decal is missing, damaged, or illegible.

ID	Decal	Description	Meaning
A		Oil Drain	Oil drain location
B		Positive Battery Cable	<ul style="list-style-type: none"> Electricity is present. Keep positive battery terminal covered at all times when connected to battery. Read and understand manuals completely before using this equipment. Identifies positive battery cable.
C		Negative Battery Cable	Identifies negative battery cable
D		Fuel Selection	<p>Step 1: Unit set for Natural Gas (NG) operation. Step 2: Press and rotate fuel selector 180° to change fuel type. Step 3: Unit set for Liquid Propane (LPG) operation.</p> <p>NOTE: This decal is intended to be discarded after installation and need not be replaced if missing.</p>
E		Shock Hazard / Read The Manual	<ul style="list-style-type: none"> Live components carrying potentially lethal voltages may be accessible inside. Render the equipment safe before attempting further access. Read and understand manuals completely before attempting further access.
F		Burn Hazard / Asphyxiation Hazard	<ul style="list-style-type: none"> Surface may be hot. Do not touch when operating equipment. After equipment shutdown, allow sufficient time for surfaces to cool prior to contact. Carbon monoxide, a colorless odorless poisonous gas, is emitted in engine exhaust while equipment is running. Avoid inhalation of exhaust gases.
G		Activation	<ul style="list-style-type: none"> Activate the generator set before putting the unit into operation. Read the manual for details.

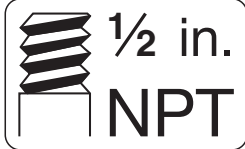
H		No User Serviceable Parts	<ul style="list-style-type: none"> • Electricity is present at various locations inside this enclosure. • This equipment is designed for automatic operation and may start at any time. Render the unit inoperable before servicing. • Battery is present. Wear appropriate protective gear. • This equipment emits exhaust gases. Ensure proper installation to prevent asphyxiation. • Do not open the enclosure. There are no user-serviceable parts inside. Contact an IASD. • Read and understand the manual completely before installing or operating this equipment. • Do not smoke near this equipment. • Do not allow open flames near this equipment.
J		Read Owner's Manual	Read the manuals for an explanation of this device.
K		Lifting Point	Install lifting attachments to this location and only locations identified as such. Do not connect lifting device directly to the lift point.
L		Pinch Point	Keep hands clear of these areas when installing the front panel or closing the roof.
M1	—	Model Data Decal	Decal Location—8 kVA units
M2	—	Model Data Decal	Decal Location—10 kVA and 13 kVA units
N	—	Fuel Data Decal	Decal Location
P		Sound Power Level	Guaranteed sound power level per Directive 2000/14/EC. See "Specifications" in the owner's manual for actual value.
Q		Threaded Connection	Fuel inlet has a 1/2 in. NPT threaded connection.

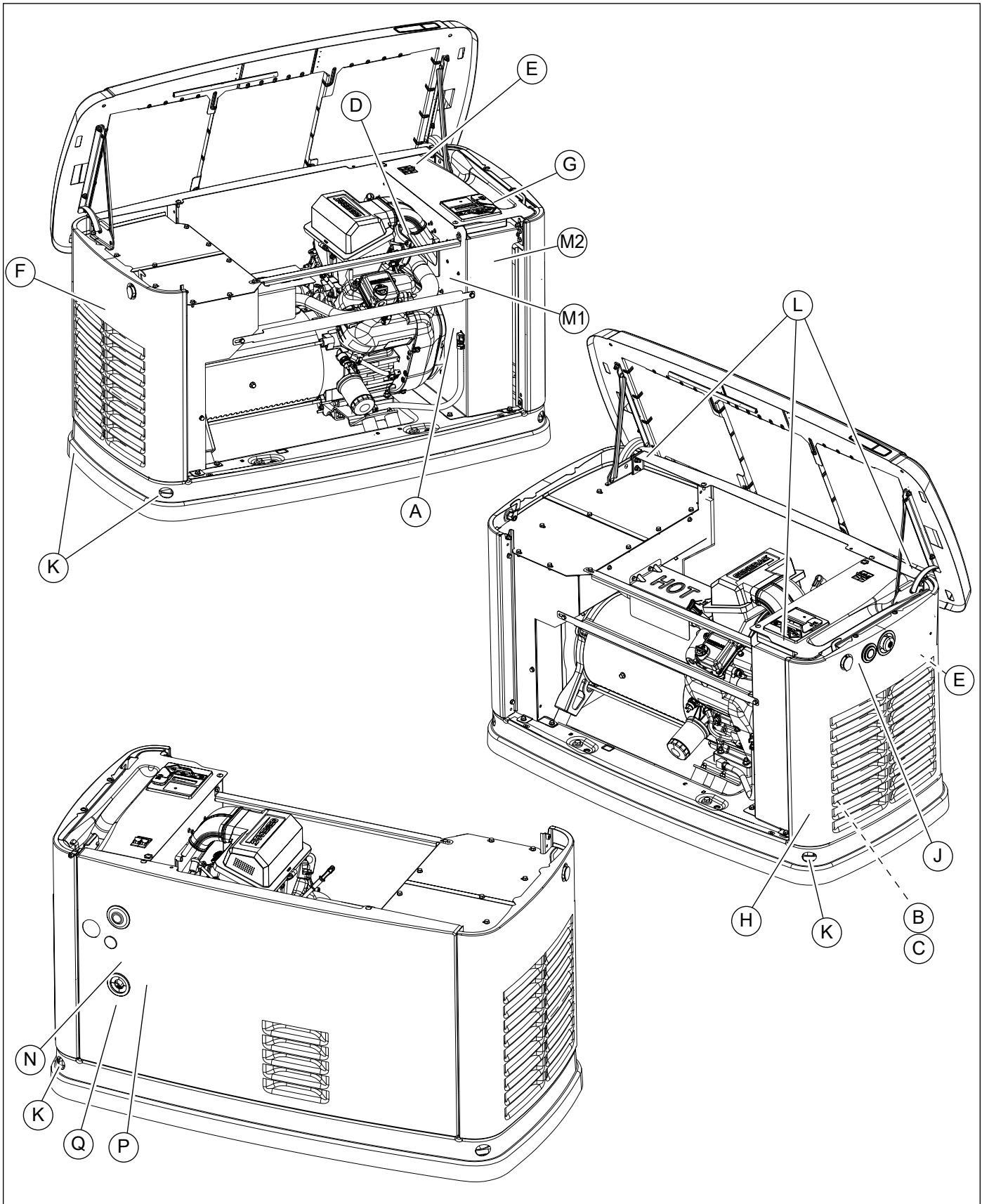

Figure 1-1. Safety and Informational Decals

Safety Rules

Study these SAFETY RULES carefully before installing, operating, or servicing this equipment. Become familiar with this manual and with the unit. The generator set can operate safely, efficiently, and reliably only if it is correctly installed, operated, and maintained. Many accidents are caused by failing to follow simple and fundamental rules or precautions.

The manufacturer cannot anticipate every possible circumstance which might involve a hazard. The alerts in this manual and on tags and decals affixed to the unit are not all-inclusive. If using a procedure, work method, or operating technique the manufacturer does not specifically recommend, verify it is safe for others and does not render the generator set unsafe.

General Safety



Hot surface. Keep equipment away from combustible materials during operation. Do not touch hot surfaces when operating equipment. After equipment shutdown, allow sufficient time for surfaces to cool prior to contact.

ISO000110



The enclosure provides protection against hot surfaces inside the generator set. Hot surfaces may be present if the generator set has been operating under a large load. Do not open the generator set enclosure while the generator set is running.

ISO000533



Read instruction manual. Read and understand manual completely before using this equipment.

ISO000100a



Refer to local codes and standards for safety equipment required when working with a live electrical system.

ISO000257



Only qualified service personnel may install, operate, and maintain this equipment.

ISO000182a



Verify the generator set is installed in accordance with the manufacturer's instructions and recommendations.

ISO000539



Following proper installation, do nothing that might alter a safe installation and render the unit in noncompliance with locally applicable codes, standards, laws, and regulations.

ISO000540



Follow all safety precautions in the owner's manual, installation manual, and other documents included with your equipment.

ISO000531



Comply with regulations the local agency for workplace health and safety has established.

ISO000538



In the event of an electrical accident, immediately shut power OFF. Use non-conductive implements to free victim from live conductor. Apply first aid and get medical help.

ISO000145



Use only fully-charged fire extinguishers rated according to applicable industry standards.

ISO000252



No open flames near equipment. Flammable and explosive gases are present inside this equipment.

ISO000529



Do not obstruct cooling and ventilating airflow around the generator set.

ISO000217



Do not stand on top of generator set or use generator set as a step.

ISO000216



The generator set must be installed and operated outdoors only.

ISO000525



No smoking near equipment. Flammable and explosive gases are present inside this equipment.

ISO000528



Fuel and vapors are extremely flammable and explosive. No leakage of fuel is permitted. Keep fire and spark away.

ISO000192



User access prohibited. Do not open the enclosure. No user serviceable parts inside. Only qualified service personnel may install, operate, and maintain this equipment. Contact an IASD.

ISO000543



Use only approved switchgear to isolate generator from the normal power source.

ISO000237

Installation



Installation must always comply with applicable codes, standards, laws, and regulations.

ISO000190



Verify electrical system is properly grounded before applying power.

ISO000152



Only a trained and licensed electrician should perform wiring and connections to unit.

ISO000155a



Installation must comply with all national and local electrical building codes.

ISO000218



Always use a battery operated carbon monoxide alarm indoors and installed according to the manufacturer's instructions.

ISO000178a



Unit must be positioned in a manner that prevents combustible material accumulation underneath.

ISO000147



Connection of fuel source must be completed by a qualified professional technician or contractor.

ISO000151a

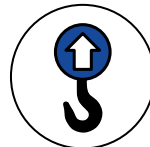

Lift point. Install lifting attachments to this location and only locations identified as such. Do not connect lifting device directly to the lift point.

ISO000532



Comply with regulations the local agency for workplace health and safety has established.

ISO000538



Verify the generator set is installed in accordance with the manufacturer's instructions and recommendations.

ISO000539



Pinch point. Keep hands clear of these areas when installing the front panel or closing the roof.

ISO000526



Following proper installation, do nothing that might alter a safe installation and render the unit in noncompliance with locally applicable codes, standards, laws, and regulations.

ISO000540



Inspect the generator set regularly, and contact the nearest servicing dealer for parts needing repair or replacement.

ISO000524



Never connect this unit to the electrical system of any building unless a licensed electrician has installed an approved transfer switch.

ISO000150



This unit is not designed for use in hazardous areas or explosive atmospheres.

ISO000547



Do not alter construction of, installation, or block ventilation for generator set.

ISO000146



Keep clothing, hair, and appendages away from moving parts.

ISO000111

Operation



This product is not intended to be used in a critical life support application.

ISO000209b



This unit is not intended for use as a prime power source. It is intended for use as an intermediate power supply in the event of a temporary power outage only.

ISO000247a



Hot surface. Keep equipment away from combustible materials during operation. Do not touch hot surfaces when operating equipment. After equipment shutdown, allow sufficient time for surfaces to cool prior to contact.

ISO000108



Do not wear jewelry when starting or operating this product.

ISO000115

Maintenance



Asphyxiating atmosphere. Carbon monoxide, a colorless odorless poisonous gas, is emitted in engine exhaust while equipment is running. Avoid inhalation of exhaust gases.

ISO000103



Batteries contain sulfuric acid and can cause severe chemical burns. Wear protective gear when working with batteries.

ISO000138a



Electricity present. Keep positive terminal covered at all times when connected to battery.

ISO000530



Electricity present. Potentially lethal voltages are generated by this equipment. Render the equipment safe before attempting repairs or maintenance.

ISO000187



Automatic start-up. Disconnect mains power and render the equipment inoperable before attempting repairs or maintenance.

ISO000191a



Do not open or mutilate batteries. Batteries contain electrolyte solution which can cause burns and blindness. If electrolyte contacts skin or eyes, flush with water and seek immediate medical attention.

ISO000163a



Avoid water contact with a power source.

ISO000104



Disconnect the negative battery cable, then the positive battery cable, when working on unit.

ISO000130



Disconnect battery ground terminal before working on battery or battery wires.

ISO000164



Always recycle batteries at an official recycling center in accordance with all local laws and regulations.

ISO000228



Batteries emit explosive gases while charging. Keep fire and spark away.

ISO000548



Do not dispose of batteries in a fire. Batteries are explosive. Electrolyte solution can cause burns and blindness. If electrolyte contacts skin or eyes, flush with water and seek immediate medical attention.

ISO000162



Do not wear jewelry when starting or operating this product.

ISO000115

Hot Surfaces



The enclosure provides protection against hot surfaces inside the generator set. Hot surfaces may be present if the generator set has been operating under a large load. Do not open the generator set enclosure while the generator set is running.

ISO000533

The generator set enclosure provides protection against hot surfaces inside the enclosure. Surfaces which may be hot while the generator set is operating are identified in **Figure 1-2**.

Follow the generator set shutdown procedure in **Shutting Generator Set Down While Under Load Or During A Mains Power (Utility) Outage** before opening the enclosure. This allows adequate cooling to reduce the risk of exposure to hot surfaces.

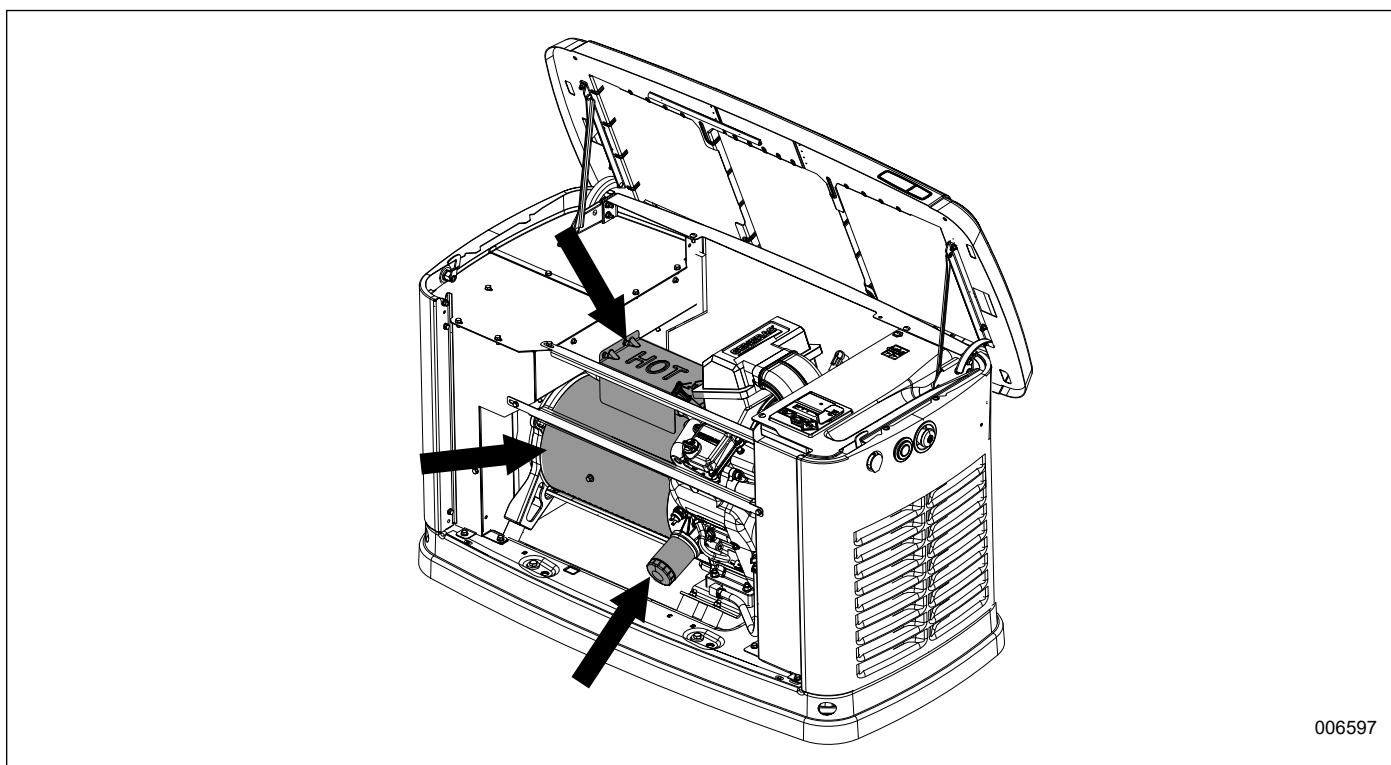

006597

Figure 1-2. Hot Surfaces

Before You Begin

- Incorrect installation can result in personal injury and damage to the generator set. It may also result in the warranty being suspended or voided. All instructions listed below must be followed, including location clearances and pipe sizes.
- Contact local inspector or city hall to be aware of all national and local codes which could impact installation. Secure all required permits before installing.
- Fully comply with all relevant NEC, OSHA, IEC, ISO, and EN standards, as well as all national and local building and electric codes. This unit must be installed in accordance with appropriate standards, and any other national and local codes for minimum distances from other structures.
- Verify capacity of NG meter or LP tank in regards to providing sufficient fuel for both the unit and other household and operating appliances.

Standards Index



This product is not intended to be used in a critical life support application.

ISO000209b

Strictly comply with all applicable national and local laws, as well as codes or regulations pertaining to the installation of this engine-generator power system. Use the most current version of applicable codes or standards relevant to the local jurisdiction, generator set used, and installation site.

NOTE: Not all codes apply to all products and this list is not all-inclusive. In the absence of pertinent local laws and standards, the following publications may be used as a guide (these apply to localities which recognize NFPA and IBC).

1. National Fire Protection Association (NFPA) 70: The NATIONAL ELECTRIC CODE (NEC) *
2. NFPA 10: Standard for Portable Fire Extinguishers *
3. NFPA 30: Flammable and Combustible Liquids Code *
4. NFPA 37: Standard for Stationary Combustion Engines and Gas Turbines *
5. NFPA 54: National Fuel Gas Code *
6. NFPA 58: Standard for Storage and Handling Of Liquefied Petroleum Gases *
7. NFPA 68: Standard On Explosion Protection By Deflagration Venting *
8. NFPA 70E: Standard For Electrical Safety In The Workplace *

9. NFPA 110: Standard for Emergency and Standby Power Systems *
10. NFPA 211: Standard for Chimneys, Fireplaces, Vents, and Solid Fuel Burning Appliances *
11. NFPA 220: Standard on Types of Building Construction *
12. NFPA 5000: Building Code *
13. International Building Code **
14. Agricultural Wiring Handbook ***
15. Article X, NATIONAL BUILDING CODE
16. ASAE EP-364.2 Installation and Maintenance of Farm Standby Electric Power ****
17. ICC:IFGC

This list is not all-inclusive. Check with the Authority Having Local Jurisdiction (AHJ) for any local codes or standards which may be applicable to your jurisdiction. The above listed standards are available from the following internet sources:

* www.nfpa.org

** www.iccsafe.org

*** www.nerc.org Rural Electricity Resource Council P.O. Box 309 Wilmington, OH 45177-0309

**** www.asabe.org American Society of Agricultural & Biological Engineers 2950 Niles Road, St. Joseph, MI 49085

Section 2: Unpacking and Inspection

General

NOTE: Carefully inspect contents for damage after unpacking. It is advised to unpack and inspect unit immediately upon delivery to detect any damage which may have occurred in transit. Any claims for shipping damage need to be filed as soon as possible with the freight carrier. This is especially important if generator set will not be installed for a period of time.

- This standby generator set is ready for installation with a factory supplied and pre-mounted base pad and has a weather protective enclosure intended for outdoor installation only.
- If any loss or damage is noted at time of delivery, have the delivery person(s) note all damage on the freight bill or affix their signature under consignor's memo of loss or damage.
- If a loss or damage is noted after delivery, separate damaged materials and contact carrier for claim procedures.
- "Concealed damage" is understood to mean damage to contents of a package not evident at time of delivery, but discovered later.

Required Tools

- General SAE and metric hand tools
 - Wrenches
 - Sockets
 - Screwdrivers
- Standard electrician's hand tools
 - Drill and bits for mounting and routing conduits
- 4 mm hex key wrench (for access to customer connections)
- 3/16 in hex key wrench (test port on fuel regulator, and E1/E2/G electrical wiring connections)
- Manometer and adapter to 1/8 in NPT (for fuel pressure checks)
- Meter capable of measuring AC/DC voltage and frequency
- Torque wrenches

NOTE: Use tools with insulated handles when working with or near electrical connections.

Unpacking

1. Remove outer shipping carton.
2. See *Figure 2-1*. Remove wood frame.

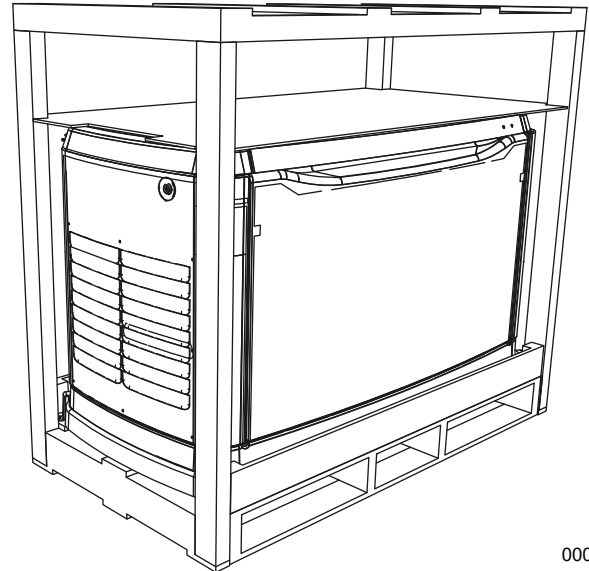

000427

Figure 2-1. Crated Generator Set

3. See *Figure 2-2*. Lid will be locked. A set of keys is attached to the cardboard sheet on top of the generator set. An additional set is attached to pallet bracket on the front intake end of the generator set. Remove keys from cardboard and pallet bracket.

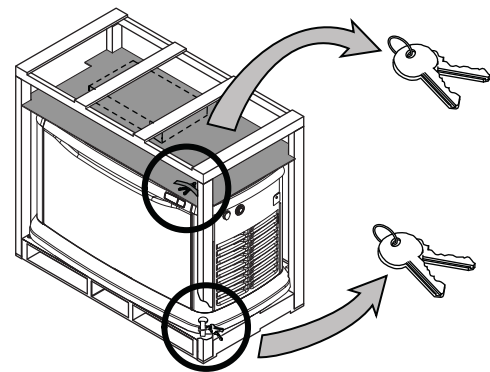

006729

Figure 2-2. Keys As Shipped

NOTE: The enclosed keys provided with this unit are intended for service personnel use only.

IMPORTANT NOTE: Do not perform this step until generator set has been transported to installation site. See *Transportation Recommendations*.

- See *Figure 2-3*. Remove bolts and pallet brackets (A). Exercise caution when removing generator set. Dragging it off the pallet will damage base. The generator set must be lifted from wooden pallet to remove.

NOTE: Bolts and pallet brackets are provided only for shipping purposes and can be discarded after removal.

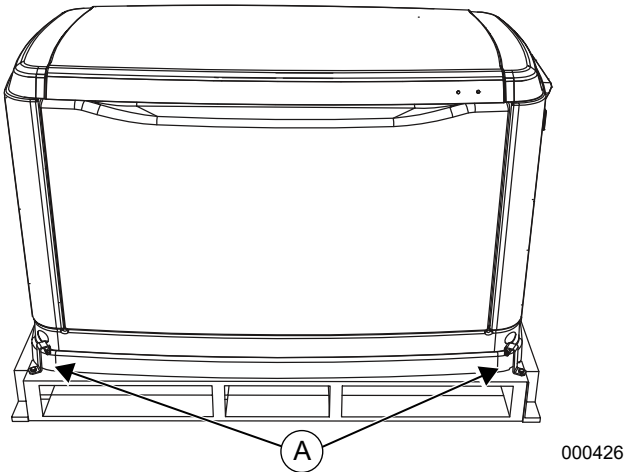

Figure 2-3. Pallet Bracket Locations

Opening The Lid

- Use keys to open generator set lid.
- See *Figure 2-4*. Two locks (A) secure lid; one on each side. Press down on lid above the side lock, and unlock latch to correctly open lid.

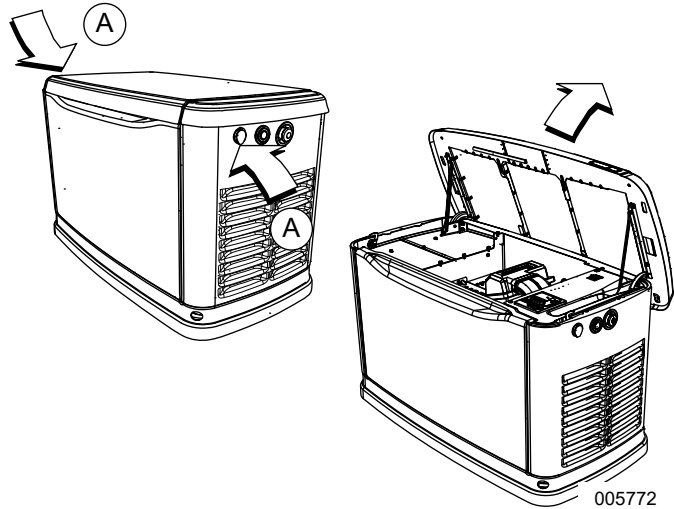

Figure 2-4. Opening The Lid

- Repeat for other side. Lid may appear stuck if pressure is not applied from the top.

NOTE: Always verify side locks are unlocked before attempting to lift lid.

Enclosure Panel Removal

Generator set installation requires removal of front panel and intake side panel. The following procedures outline the removal process. Remove these panels when necessary.

Front Access Panel Removal

See *Figure 2-5*. Remove front access panel (A) by lifting straight up and out once lid is open.

NOTE: Always lift front access panel straight up before pulling it away from enclosure. Do not pull panel away from enclosure before lifting up (B).

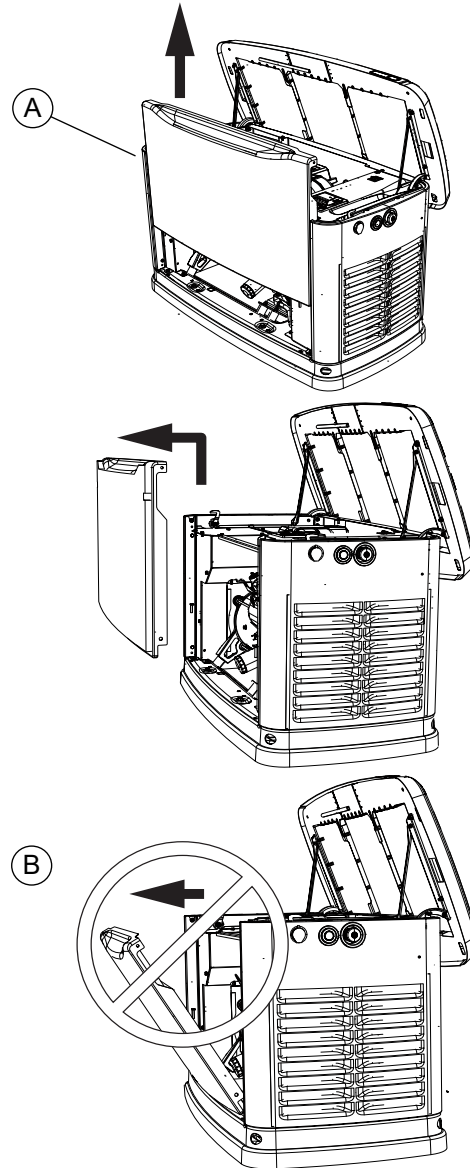

Figure 2-5. Remove Front Access Panel

Intake Side Panel Removal

See **Figure 2-6**. Intake side panel (B) must be removed to access battery compartment, fuel regulator, and sediment trap.

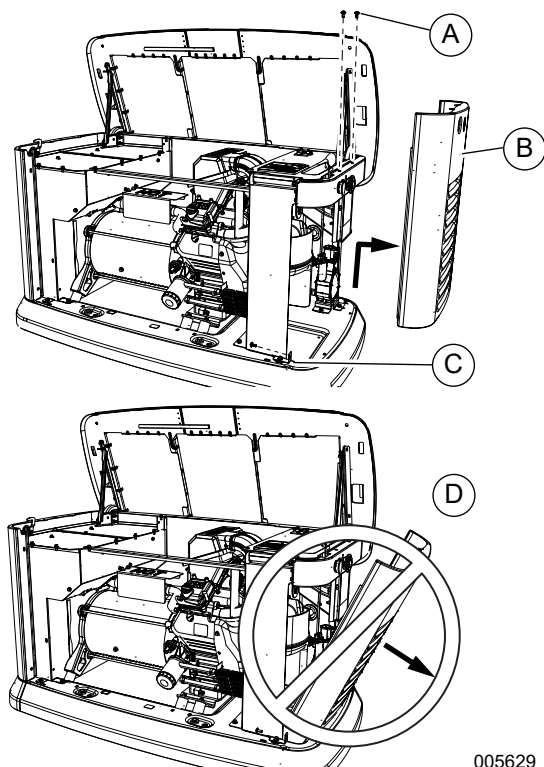

Figure 2-6. Remove Intake Side Panel

1. Raise lid and remove front panel.
2. Use 4mm hex key to remove two mounting screws (A) and L-bracket screw (C).
3. Lift intake panel up and away from generator set.
4. Inspect for any hidden freight damage. Contact freight carrier if damage is present.

NOTE: Always lift intake side panel straight up before pulling away from enclosure. Do not pull panel away from enclosure before lifting up (D).

Customer Connections and Loose Parts

See **Figure 2-7** and **Figure 2-8** for customer connections and loose parts location. **Figure 2-10** illustrates parts shipped loose.

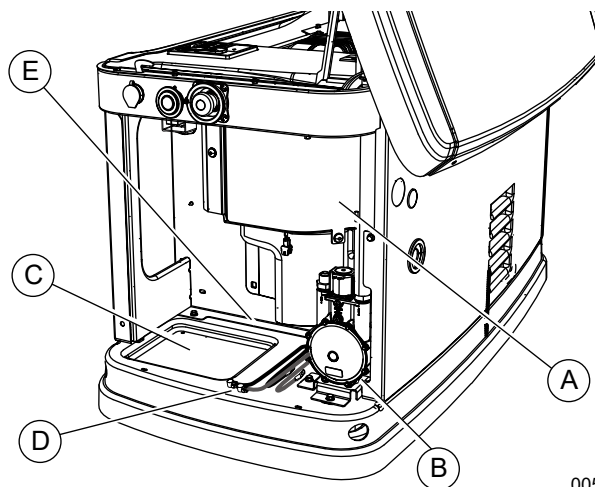

005773

A	Customer electrical connection area (behind access panel)
B	Fuel regulator with sediment trap
C	Battery compartment (battery not supplied)
D	Positive (+) and negative (-) battery cables
E	Location of "Loose Shipped Parts"

Figure 2-7. Customer Connection Area and Loose Parts Location

Rear Connections

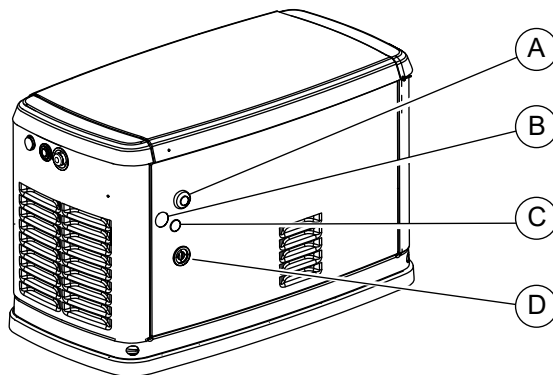

005774

A	Wi-Fi module
B	Main AC/Control wiring hole for 1-1/4 in conduit
C	Main AC/Control wiring hole for 3/4 in conduit
D	Fuel connection hole

Figure 2-8. Rear Connections

Generator Main Line Circuit Breaker

See **Figure 2-9**. This is a 2-pole circuit breaker (generator disconnect) (A) rated according to relevant specifications.

Indicator (B) Identifier—Green means OFF (OPEN). Red means ON (CLOSED).

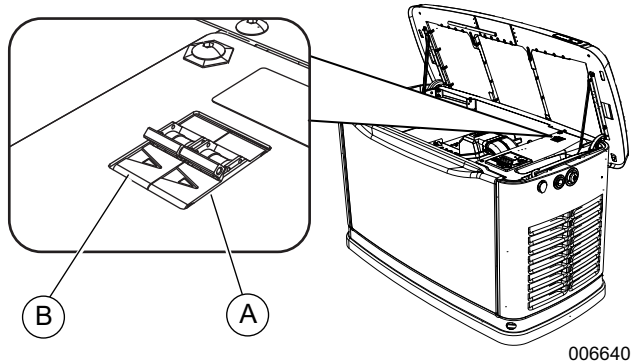

006640

Figure 2-9. Generator Main Line Circuit Breaker (MLCB)

Parts Shipped Loose

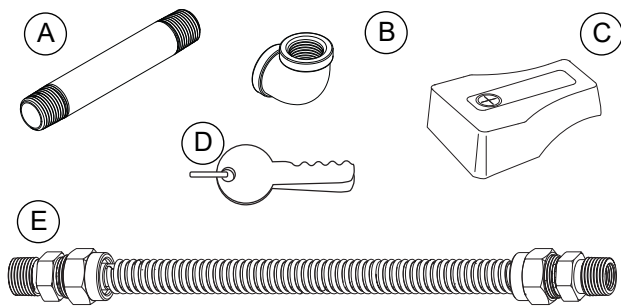

005966

A*	Pipe nipple, 1/2 in NPT x 5 in
B*	Elbow, 90°, 1/2 in NPT
C	Battery terminal cap
D	Keys
E	Flexible fuel line
F	Owner's, installation, and Wi-Fi manuals (not shown)
* Used for connection between generator set fuel inlet and flexible fuel line.	

Figure 2-10. Parts Shipped Loose

Section 3: Site Selection and Preparation

Site Selection

Site selection is critical for safe generator set operation. It is important to discuss these factors with the installer when selecting a site for generator set installation:

- Carbon monoxide
- Fire prevention
- Fresh air for ventilation and cooling
- Water ingress prevention
- Proximity to utilities
- Suitable mounting surface

The following pages describe each of these factors in detail.

NOTE: The term “structure” is used throughout this section to describe the home or building where the generator set is being installed. Illustrations depict a typical residential home. However, instructions and recommendations presented in this section apply to all structures regardless of type.

Carbon Monoxide



Asphyxiating atmosphere. Carbon monoxide, a colorless odorless poisonous gas, is emitted in engine exhaust while equipment is running. Avoid inhalation of exhaust gases.

ISO000103

IMPORTANT NOTE: Move to fresh air immediately and seek medical attention if you feel sick, dizzy, or weak while generator set is running or after it stops.

Generator set exhaust contains carbon monoxide (CO)—a poisonous, potentially lethal gas that cannot be seen or smelled. The generator set must be installed in a well ventilated area away from windows, doors, and openings. The selected location must not allow exhaust gases to be drawn into structures where people or animals may be present.

Carbon Monoxide Detectors

See [Figure 3-1](#). CO detectors (K) must be used to monitor for CO and to warn individuals about the presence of CO. CO detectors should be installed and tested in accordance with the CO detector manufacturer’s instructions and warnings. Contact local building inspection department for any applicable requirements concerning CO detectors.

IMPORTANT NOTE: Common smoke alarms do NOT detect CO gas. Do not rely on smoke alarms to protect residents or animals from CO. The only way to detect CO is to have functioning CO alarms.

Potential CO Entry Points

See **Figure 3-1**. Generator set exhaust can enter a structure through large openings, such as windows and doors. However, exhaust and CO can also seep into the structure through smaller, less obvious openings.

Protect the Structure

Verify structure itself is correctly caulked and sealed to prevent air from leaking in or out. Voids, cracks, or openings around windows, doors, soffits, pipes, and vents can allow exhaust gas to be drawn into the structure.

Some examples of potential entry points are described and included in, but not limited to, the accompanying table.

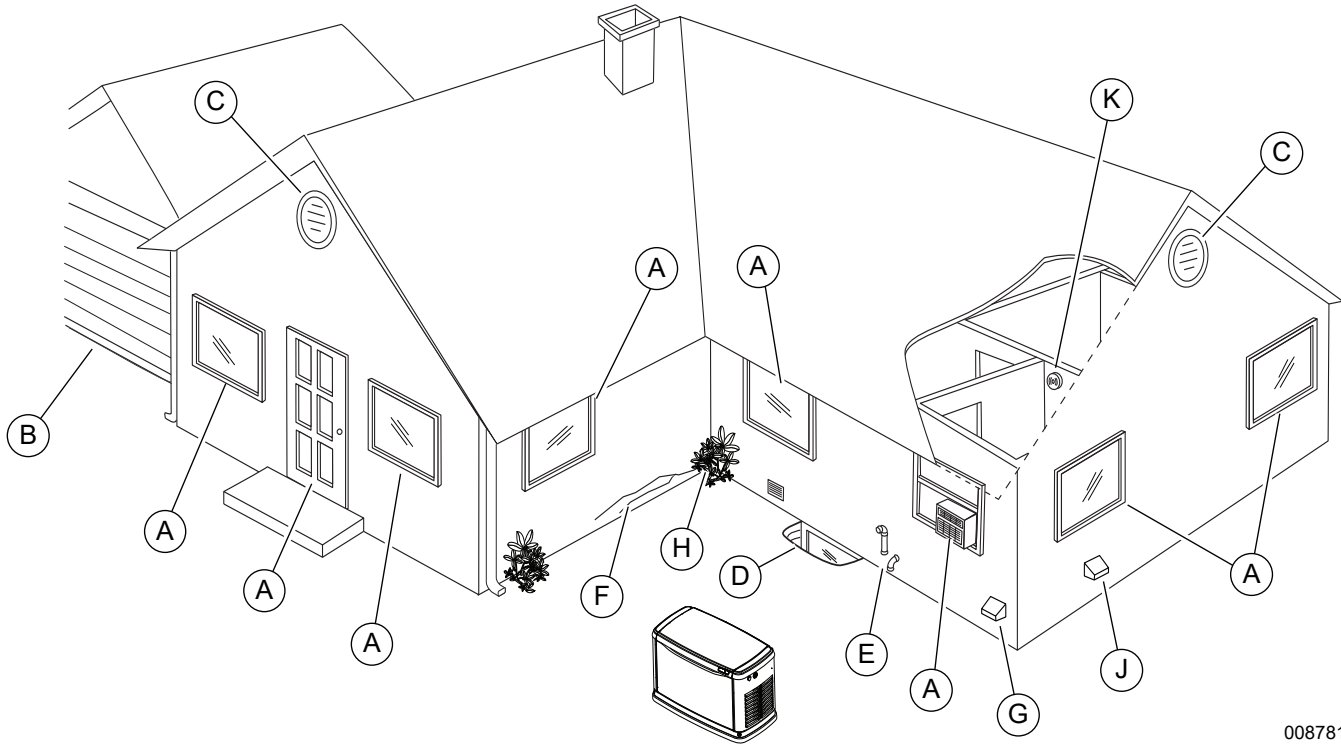

008781

Figure 3-1. Carbon Monoxide—Potential Entry Points

ID	Entry Point	Description / Comments
A	Windows and doors	Architectural details which can be (or are) opened to admit fresh air into the structure.
B	Garage door	CO can leak into garage if door is open, or does not seal correctly when closed.
C	Attic vent	Attic vents, ridge vents, crawl space vents, and soffit vents can all admit generator exhaust.
D	Basement windows	Windows or hatches allowing ventilation to or from lower level of a structure.
E	Furnace intake / exhaust vent	Air intake and exhaust pipes for furnace.
F	Wall cracks	Includes (but not limited to) cracks in wall, foundation, mortar, or air gaps around doors, windows, and pipes. See Protect the Structure .
G	Dryer vent	Exhaust duct for clothes dryer.
H	Airflow restrictions	Structural corners and locations with heavy vegetation restrict airflow. Exhaust gases can collect in such areas.
J	Make up air system	IMPORTANT NOTE: Mechanical and gravity outdoor air intake openings for HVAC supply air systems shall be located not less than 10 feet (3048mm) horizontally from the generator enclosure. See Section 401 in the ICC Mechanical Code for any additional requirements.

Fire Prevention

The generator set must be installed at a safe distance away from combustible materials. Engine, alternator, and exhaust system components become very hot during operation. Fire risk increases if unit is not correctly ventilated, is not correctly maintained, operates too close to combustible materials, or if fuel leaks exist. Also, accumulations of flammable debris within or outside the generator set enclosure may ignite.

Distance Requirements

See [Figure 3-2](#). Minimum clearances must be maintained around generator set enclosure. These clearances are primarily for fire prevention, but also to provide sufficient room for removing front and end panels for maintenance purposes.

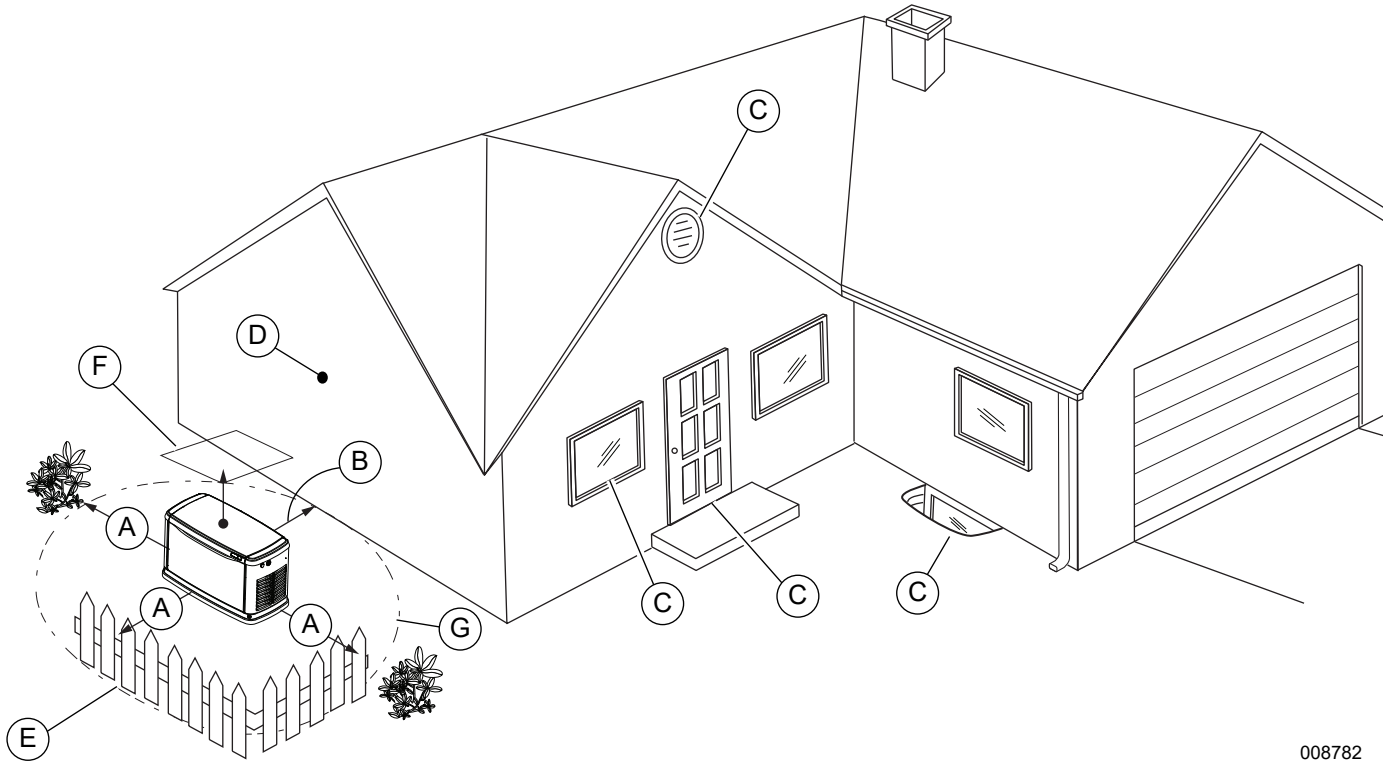

008782

Figure 3-2. Generator Set Distance Requirements

ID	Description	Definition
A	Front and end clearance	Minimum clearance from the front and ends of the generator set must be 0.91 m (3 ft). This includes shrubs, bushes, and trees.
B	Rear clearance	Fuel and electrical connections are made here. 457 mm (18 in) minimum clearance per NFPA testing, labeling, and listing, unless state or local codes dictate otherwise.
C	Windows, vents, and openings	No operable windows, doors, vents, window wells, or openings in the wall are permitted near any point of the generator set. See Potential CO Entry Points for more information.
D	Existing wall	The generator set cannot be placed closer than 457 mm (18 in) from existing walls.
E	Removable fence	A removable barrier (non-permanent; without footings) installed as a visual surround. Removable fence panels for servicing cannot be placed less than 0.91 m (3 ft) in front of the generator set.
F	Overhead clearance	1.52 m (5 ft) minimum distance from any structure, overhang, or projections from wall. DO NOT install under wooden decks or structures.
G	Maintenance and servicing	Maneuvering space around generator set for performing routine maintenance tasks such as battery replacement and engine service. Do not attempt to conceal generator with shrubs, bushes, or plants.

Fire Codes, Standards, and Guidelines

Generator set installation must comply strictly with ICC IFGC, NFPA 37, NFPA 54, NFPA 58, and NFPA 70 standards. These standards prescribe the minimum safe clearances around and above the generator set enclosure.

NFPA 37

NFPA 37 is the The National Fire Protection Association’s standard for the installation and use of stationary combustion engines. Its requirements limit the spacing of an enclosed generator set from a structure or wall, and require generator to be located where it is readily accessible for maintenance, repair, and first responders.

NFPA 37, Section 4.1.4, Engines Located Outdoors: Engines, and their weatherproof housings if provided, installed outdoors shall be located at least 1.52 m (5 ft) from openings in walls and at least 1.52 m (5 ft) from structures having combustible walls. A minimum separation shall not be required where the following conditions exist:

1. The adjacent wall of the structure has a fire resistance rating of at least one hour.
2. The weatherproof enclosure is constructed of non-combustible materials and it has been demonstrated that a fire within the enclosure will not ignite combustible materials outside the enclosure.

Annex A—Explanatory Material

A4.1.4 (2) Means of demonstrating compliance are by means of full scale fire test or by calculation procedures.

Because of limited spaces frequently available for installation, it has become apparent that exception (2) would be beneficial for many residential and commercial installations. The manufacturer contracted with an independent testing laboratory to run full scale fire tests.

NOTE: The Southwest Research Institute (SwRI) is a nationally recognized third party testing and listing agency. SwRI testing approves 457 mm (18 in) installation minimum from rear panel of the generator set to an adjacent structure for fire protection.

The criteria was to determine the worst case fire scenario within the generator set and to determine ignitability of items outside engine enclosure at various distances. The enclosure is constructed of non-combustible materials, and the results and conclusions from the independent testing lab indicated that any fire within the generator set enclosure would not pose any ignition risk to nearby combustibles or structures, with or without fire service personnel response.

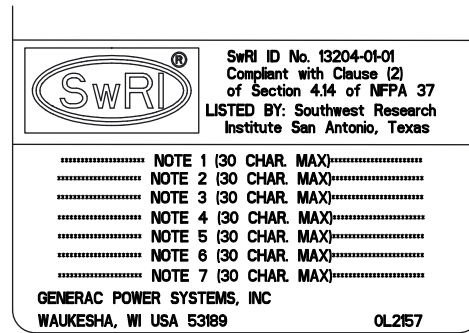

002158

Figure 3-3. Southwest Research Institute Marking

<http://www2.swri.org/www2/listprod/DocumentSelection.asp?ProductID=973&IndustryID=2>

Based on this testing and the requirements of NFPA 37, Sec 4.1.4, the guidelines for installation of the generator sets listed above are changed to 457 mm (18 in) from the back side of the generator set to a stationary wall or building. For adequate maintenance and airflow clearance, the area above the generator set should be at least 1.52 m (5 ft) with a minimum of 0.91 m (3 ft) at the front and ends of the enclosure. This includes trees, shrubs, and bushes. Vegetation not in compliance with these clearance parameters could obstruct air flow. In addition, exhaust fumes from the generator set could inhibit plant growth. See **Figure 3-2** and the accompanying descriptions.

Generator Set Maintenance

Regular maintenance is crucial for minimizing exhaust emissions and reducing the risk of fire or equipment failure. For example:

- A dirty air filter or low engine oil level may cause the engine to overheat.
- Incorrect spark plug gaps may cause engine backfiring and incomplete combustion.

IMPORTANT NOTE: See Maintenance section of generator set owner’s manual to view a table of scheduled maintenance tasks and procedures. Perform all maintenance tasks as directed.

Fresh Air for Ventilation and Cooling

Install the unit where air inlet and outlet openings will not become obstructed by leaves, grass, snow, etc. If prevailing winds will cause blowing or drifting, consider using a windbreak at a safe distance to protect the unit.

Water Ingress Avoidance

- Choose a location on high ground where water levels will not rise and flood the generator set. This unit should not operate in, or be subjected to, standing water.
- Install the unit where rain gutter downspouts, roof run-off, landscape irrigation, water sprinklers, or sump pump discharge does not flood the unit or spray the enclosure, including any air inlet or outlet openings.
- Excess moisture can cause excess corrosion and decrease the life expectancy of the unit.

Proximity to Utilities

- Install the unit where services will not be affected or obstructed, including concealed, underground, or covered services such as electrical, fuel, phone, air conditioning, or irrigation. This could affect warranty coverage.
- Remember that laws and or codes may regulate the distance and location of the unit to specific utilities.
- It is recommended to pick a location such that the generator set is as close as possible to the transfer switch and the fuel supply, while verifying the site location conforms to the rest of the Site Selection section.

Verify Wi-Fi Range

See Wi-Fi manual shipped with unit if planning to use the Wi-Fi feature.

Transportation Recommendations

Use a suitable cart or equipment to carry the generator set, including wooden pallet, to the installation site. Place cardboard between cart and generator set to prevent any damage or scratches to generator set.

Do not lift, carry, or move generator set by grasping the louvers. Doing so may bend or damage the sheet metal.

Suitable Mounting Surface

See *Figure 3-4*. Prepare a rectangular area approximately 127 mm (5 in) deep (A) and approximately 72.6 mm (3 in) longer and wider (B) than all sides of the generator set.

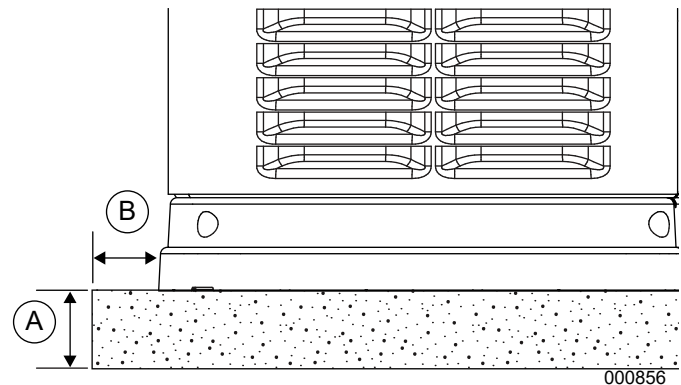

Figure 3-4. Compacted Gravel or Concrete Pad

Select base type as desired or as required by local laws or codes. The generator set is typically placed on pea gravel, compacted soil, crushed stone, or a concrete pad. Follow all applicable codes if a concrete pad is required.

Verify surface where generator set will be mounted is compacted, leveled, and will not erode over time. Generator set must be level within 13 mm (0.5) in all around.

Placement on Roofs, Platforms, and Other Supporting Structures

Where required to place generator on a roof, platform, deck, or other supporting structure, generator must be placed in accordance with the requirements in NFPA 37, Section 4.1.3. Generator can be located 457 mm (18 in) from structures having combustible walls and 1.52 m (5 ft) from any operable opening in the structure. Surface beneath the generator and beyond must be noncombustible to a minimum distance of 30.5 cm (12 in). Contact local Building Inspection Department or fire department to determine which noncombustible materials are approved for installation.

This page intentionally left blank.

Section 4: Generator Set Placement

Generator Set Weight (kg / lb)

8 kVA	10 kVA	13 kVA
154.7 / 341	176.4 / 389	192.8 / 425

Lifting Instructions

Once generator set is at the prepared installation site, lift generator set off wood pallet and place on prepared area.

See [Figure 4-1](#). Generator set base has four holes (A) for suitable lifting attachments.

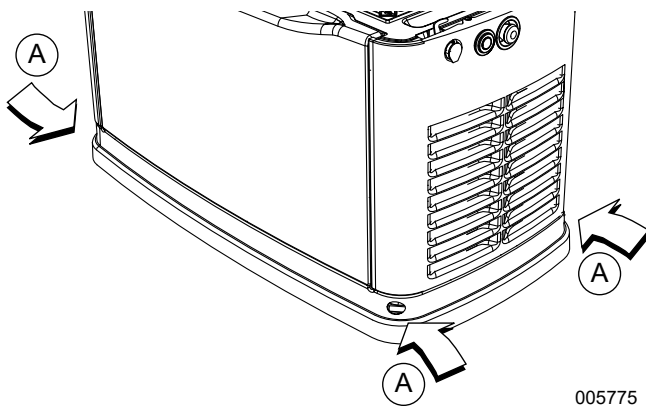

Figure 4-1. Lift Points

Proceed as follows to prepare generator set to be lifted:

1. Verify all panels are securely installed and lid is locked in closed position.
2. See [Figure 2-3](#). Verify all four pallet brackets have been removed.
3. See [Figure 4-2](#). Insert two 25 mm (1 in) diameter rods (B) with a minimum length of 1 m (3.3 ft) through the holes in the generator set base; one at each end. Verify rods are centered with an equal length protruding from each hole.

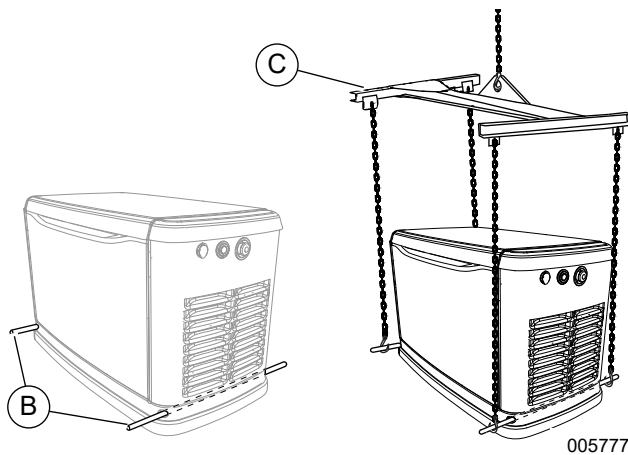

Figure 4-2. Attach Lifting Gear

4. Use appropriately-sized chains or lifting straps to connect a four-point spreader bar (C) to the rods.
 5. Connect four-point spreader bar to lifting device.
- The unit is now ready to be lifted.

Generator Set Placement

See [Figure 4-3](#). All air-cooled generator sets come with a composite pad. The composite pad elevates the generator set and helps prevent water from pooling around base.

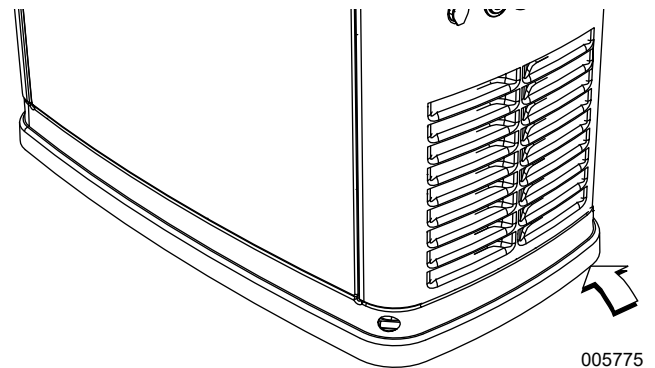

Figure 4-3. Composite Pad

The composite pad allows the generator set to be placed on two types of surfaces:

- on 127 mm (5 in) of compacted pea gravel or crushed stone
- on a concrete pad

See local codes for what type of site base is required. If a concrete pad is required, all federal, state, and local codes must be followed. Place generator set, with composite pad attached, and position correctly as per the dimensional information given in [Site Selection and Preparation](#).

NOTE: Generator set must be level within 13 mm (0.5 in).

NOTE: DO NOT remove composite pad for mounting generator set to concrete. The composite pad is pre-drilled to accommodate mounting bolts.

See [Figure 4-4](#). Three mounting holes are available if codes require securing the generator set to the concrete. Two holes are inside the front of the generator compartment, and one hole in back.

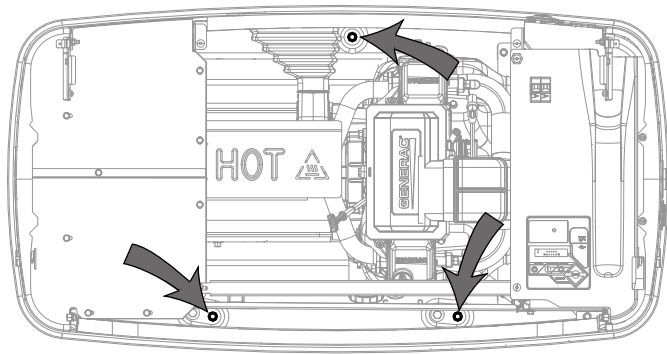

005776

Figure 4-4. Mounting Hole Location

Three M10 (or 3/8 in) lag bolts (not supplied) are recommended for securing the generator set to a concrete pad.

NOTE: The top of the generator set carton has a template which can be used to mark the concrete pad to pre-drill the mounting holes.

Section 5: Fuel Conversion / Gas Connections

Fuel Requirements and Recommendations



Fuel and vapors are extremely flammable and explosive. No leakage of fuel is permitted. Keep fire and spark away.

ISO000192

NOTE: NG is lighter than air and will collect in high areas. LP gas is heavier than air and will settle in low areas.

LP gas should only use a vapor withdrawal system. This type of system uses vapors formed above liquid propane in the storage tank.

The unit will run on NG or LP gas, but has been factory-configured to run on NG.

NOTE: Should the primary fuel need to be changed to LP gas, the fuel system needs to be reconfigured. See [Fuel Conversion](#) for instructions on converting the fuel system.

BTU Content

Recommended fuels should have a MJ/BTU content of at least 37.26 MJ/m³ (1,000 BTU/ft³) for NG; or at least 93.15 MJ/m³ (2500 BTU/ft³) for LP gas.

NOTE: MJ/BTU fuel content information is available from the fuel supplier.

Fuel Pressure

Required fuel pressure for NG is 0.87–1.74 kPa (3.5–7.0 in water column) at the generator set fuel inlet. Required fuel pressure for LP gas is 2.49–2.99 kPa (10–12 in water column) at the generator set fuel inlet.

NOTE: The primary regulator for LP gas supply is NOT INCLUDED with the generator set.

NOTE: All pipe sizing, construction, and layout must comply with all applicable codes, standards, laws, and regulations pertaining to NG or LP gas applications. Verify fuel pressure NEVER drops below required specification once generator set is installed.

Always contact local fuel suppliers or fire marshal to verify codes and regulations for correct installation. Local codes will mandate correct routing of gaseous fuel line piping around gardens, shrubs, and other landscaping.

Piping strength and connections should be given special consideration when installation takes place in areas at risk for; flooding, tornadoes, hurricanes, earthquakes, and unstable ground.

IMPORTANT NOTE: Use an approved pipe sealant or joint compound on all threaded NPT fittings.

NOTE: All installed gaseous fuel piping must be purged and leak tested prior to initial startup in accordance with local codes, standards, and regulations.

Fuel Conversion

Proceed as follows to convert from NG configuration to LP gas:

See [Figure 5-1](#). The orange fuel conversion knob (A) is located above the fuel mixer.

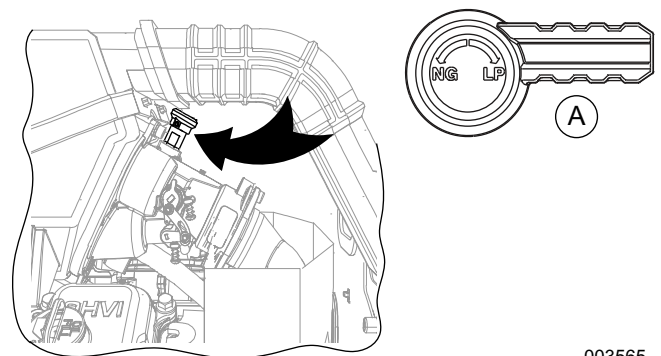

003565

Figure 5-1. Fuel Conversion Knob Location

See [Figure 5-2](#). A fuel selection hang tag is attached to the fuel conversion knob. As shown on the tag, in Step 1 the unit is factory-set for NG operation. To change fuel type to LP gas, press and turn fuel conversion knob (Step 2) towards marked LP fuel source arrow until it stops. Step 3 shows fuel conversion knob in LP gas position.

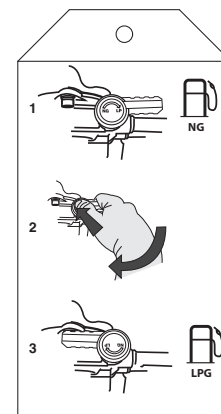

006598

Figure 5-2. Fuel Conversion Hang Tag

NOTE: The fuel selection (LP/NG) must be entered on the controller during initial power up using the [Install Wizard Menu Map](#) navigation menu, or in the EDIT menu under “Fuel Selection.”

Fuel Consumption

Generator Set Rating	Natural Gas		Propane	
	1/2 Load	Full Load	1/2 Load	Full Load
8 kVA	2.21 / 78	3.62 / 128	3.29 / 0.87 / 0.89	6.16 / 1.63 / 1.68
10 kVA	3.51 / 124	5.30 / 187	4.79 / 1.26 / 1.30	7.62 / 2.01 / 2.07
13 kVA	4.02 / 142	6.48 / 229	5.58 / 1.47 / 1.52	8.86 / 2.34 / 2.41

* Natural gas is in m³/h / ft³/h

** Propane is in L/h (LP) / gal/h (LP) / m³/h (LPG)

*** Values given are approximate

These are approximate values. Use the appropriate spec sheet or owner's manual for specific values.

Verify gas meter is capable of providing enough fuel flow to include household appliances and all other loads.

NOTE: The fuel supply and pipe MUST be sized at 100% load BTU/h (Megajoule/h) rating.

Always see the Fuel Data Decal on the generator set for the correct Megajoule/h requirement. The formulas listed below can be used to estimate the BTU/h or Megajoule/h requirement:

– Natural Gas:

$$\text{BTU/h} = \text{ft}^3/\text{h} \times 1000$$

$$\text{Megajoules/h} = \text{m}^3/\text{h} \times 37.26$$

– Liquid Propane Gas:

$$\text{BTU/h} = \text{ft}^3/\text{h} \times 2500$$

$$\text{Megajoules/h} = \text{m}^3/\text{h} \times 93.15$$

Fuel Line Sizing

Selecting the correct size fuel line is crucial to the correct operation of the unit.

IMPORTANT NOTE: Generator set inlet size DOES NOT dictate size of gas pipe to be used!

For further information, see applicable codes, standards, laws, and regulations for NG and LP gas.

Measure distance from generator set to fuel source.

IMPORTANT NOTE: The generator set should be plumbed directly from fuel source, not off the end of an existing low pressure system.

Natural Gas Pipe Sizing

To determine correct NG pipe size, find the kVA rating of the generator set in the left column, and trace to the right. The number to the right is maximum length (measured in m / ft) allowed for the pipe sizes on top. Pipe sizes are measured by trade size diameter to include any fittings, valves (must be full flow), elbows, tees, or angles.

NOTE: See Table B.3.2 in NFPA 54 or Table A.2.2 in the ICC IFGC, Equivalent Lengths of Pipe Fittings and Valves for the correct values to be added to overall fuel piping length. Tables based on schedule 40 black pipe. If installing any other piping system, follow the pipe sizing charts for the selected piping system.

Table 5-1. NG Pipe Sizing

Pipe Size (mm / in)	For 1.24–1.74 kPa (5–7 in water column)				For 0.87–1.24 kPa (3.5–5 in water column)		
	Allowable Pipe Distances (m / ft)						
	19 / 0.75	25 / 1	32 / 1.25	38 / 1.5	25 / 1	32 / 1.25	38 / 1.5
8 kVA	6.1 / 20	25.91 / 85	112.78 / 370	243.84 / 800	9.14 / 30	38.1 / 125	60.96 / 200
10 kVA	3.05 / 10	15.24 / 50	74.68 / 245	166.12 / 545	6.1 / 20	24.38 / 80	53.34 / 175
13 kVA	—	12.19 / 40	57.91 / 190	129.54 / 425	3.05 / 10	18.29 / 60	38.1 / 125

LP Gas Pipe Sizing

To determine correct LP gas pipe size, find the kVA rating of the generator set in the left column, and trace to the right. The number to the right is maximum length (measured in m / ft) allowed for the pipe sizes on top. The pipe sizes are measured by trade size diameter to include any fittings, valves (must be full flow), elbows, tees, or angles. See Table B.3.2 in NFPA 54 or Table A.2.2 in the ICC IFGC, Equivalent Lengths of Pipe Fittings and Valves for the correct values to be added to overall fuel piping length.

NOTE: Pipe sizes are from the outlet of the second stage regulator to the fuel shutoff valve. Table is based on schedule 40 black pipe. If installing any other piping system, follow the pipe size charts for the selected piping system.

NOTE: Recommended minimum LP gas tank size is 946 L (250 gal). Contact LP provider to correctly size LP tank to generator. Vertical tanks, which are measured in kilograms (or pounds), are permitted if correctly sized for the generator set. Do not connect generator to a 20 or 30 lbs LP tank.

Table 5-2. LP Gas Pipe Sizing

Pipe Size (mm / in)	For 2.49–2.99 kPa (10–12 in water column)		
	Allowable Pipe Distances (m / ft)		
	19 / 0.75	25 / 1	32 / 1.25
8 kVA	21.33 / 70	77.72 / 255	304.8 / 1000
10 kVA	13.72 / 45	51.82 / 170	210.31 / 690
13 kVA	7.62 / 25	39.62 / 130	164.59 / 540

Installing and Connecting Fuel Lines



Fuel and vapors are extremely flammable and explosive. No leakage of fuel is permitted. Keep fire and spark away.

ISO000192

IMPORTANT NOTE: NG and LP gas are highly volatile substances. Strictly adhere to all safety procedures, codes, standards, and regulations.

IMPORTANT NOTE: The fuel inlet to the generator set has NPT threads. NPT threads are tapered and require the use of pipe thread sealant.

Fuel line connections should be made by a certified contractor familiar with local codes. Always use AGA-approved gas pipe and a quality pipe sealant or joint compound.

Verify capacity of NG meter or LP tank to provide sufficient fuel for both the generator set and other operating appliances.

Fuel Shutoff Valve

See [Figure 5-3](#). Local codes, standards, or regulations may require an external manual fuel shutoff valve (A) to be installed on the fuel supply line to the generator set. The fuel shutoff valve must be readily accessible. The installer is responsible for supplying this fuel shutoff valve.

NOTE: Fuel shutoff valve must be installed at a readily accessible location, and within 1.8 m (6 ft) of generator fuel inlet.

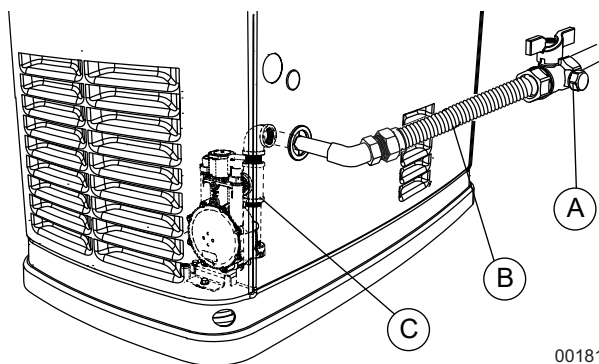

001816

Figure 5-3. Sediment Trap, Fuel Shutoff Valve with Manometer Port, and Flexible Fuel Line

NOTE: [Figure 5-4](#) illustrates a fuel shutoff valve with a manometer port for making fuel pressure checks. This optional accessory fuel shutoff valve permits making pressure checks for diagnostic purposes without going into the generator set enclosure.

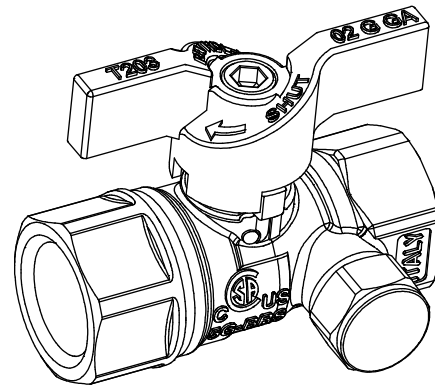

000743

Figure 5-4. Fuel Shutoff Valve with Manometer Port

Flexible Fuel Line

See [Figure 5-3](#). The generator set requires a flexible connection to the fuel supply line. A flexible fuel line (B) with NPT threads is included. The installer must verify that any component used to connect the generator set to fuel supply meets the requirements of all applicable codes, standards, laws, and regulations.

The flexible fuel line must not be connected directly to the generator set fuel inlet. Always connect flexible fuel line to an approved gas fitting.

The purpose of flexible fuel line is to isolate vibration from the generator set to reduce possibility of a gas leak at one of the connection points.

NOTE: Follow all installation instructions and warnings provided with the flexible fuel line. Do not remove any labels or tags.

NOTE: Flexible fuel line must be installed horizontally and has to be installed between the fuel shutoff valve and generator fuel inlet.

Sediment Trap

See [Figure 5-3](#). Some local codes require a sediment trap (C). The fuel regulator has an integrated sediment trap with a 1/2 in NPT inlet for fuel supply connection.

The sediment trap must be cleaned periodically according to local codes. See owner's manual for more information.

Checking Fuel Line Connections

Checking Fuel Pressure

Proceed as follows to check fuel pressure at the regulator in the generator set:

1. Close fuel supply valve.
2. See **Figure 5-5**. Remove the 1/8 in NPT plug from top fuel pressure test port in the regulator and install fuel pressure tester (manometer).

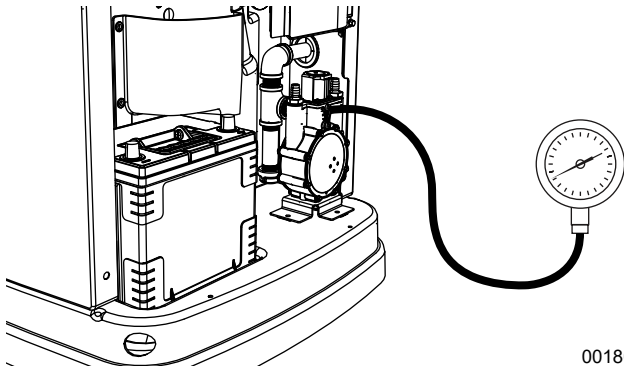

001807

Figure 5-5. Checking Fuel Pressure with Manometer

NOTE: Connection to fuel pressure test port requires a fitting with 1/8 in NPT thread.

3. Open fuel supply valve and verify fuel pressure is within the specified values.
4. Record static fuel pressure: _____

NOTE: Fuel pressure can also be tested at the manometer port on the fuel shutoff valve shown in **Figure 5-4**.

NOTE: See owner's manual or spec sheet for required fuel pressure specifications. Contact local gas supplier if the fuel pressure is not within specifications.

5. Close fuel valve when completed. Keep manometer connected for future tests of generator set while starting, running, and under loads.

Performing Fuel System Leak Test



Fuel and vapors are extremely flammable and explosive. No leakage of fuel is permitted. Keep fire and spark away.

ISO000192

All products are factory-tested before shipping to verify performance and integrity of the fuel system. However, it is important to perform a final fuel system leak test before starting the generator set. The entire fuel system should be tested from supply to regulator.

See **Figure 5-6**. Perform a final fuel system leak test after generator set installation. The test will identify possible leaks at all connection points (A).

It is best practice to perform a fuel system leak test during normally-scheduled maintenance.

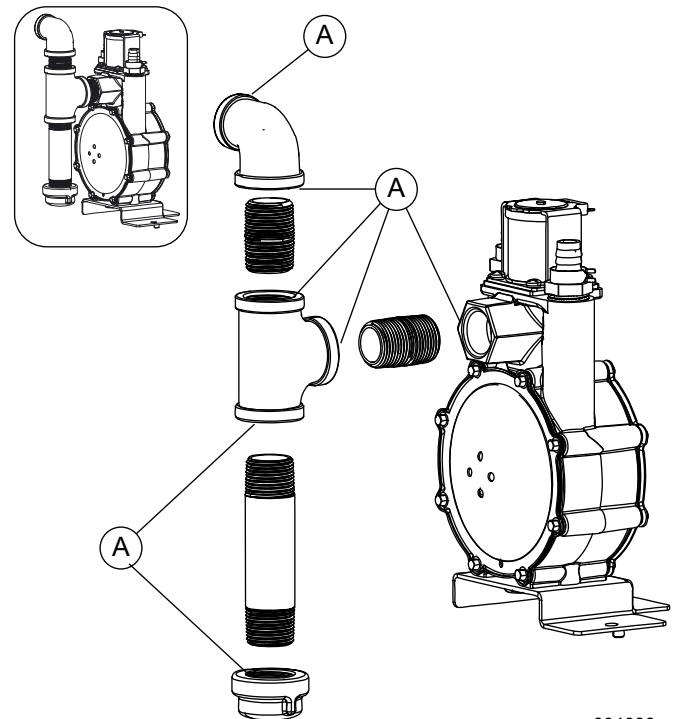

004038

Figure 5-6. Connection Points to Leak Check

Inspect for leaks by spraying all connection points with a non-corrosive gas leak detection fluid. The solution should not be blown away or form bubbles.

Natural Gas Installation (Typical)

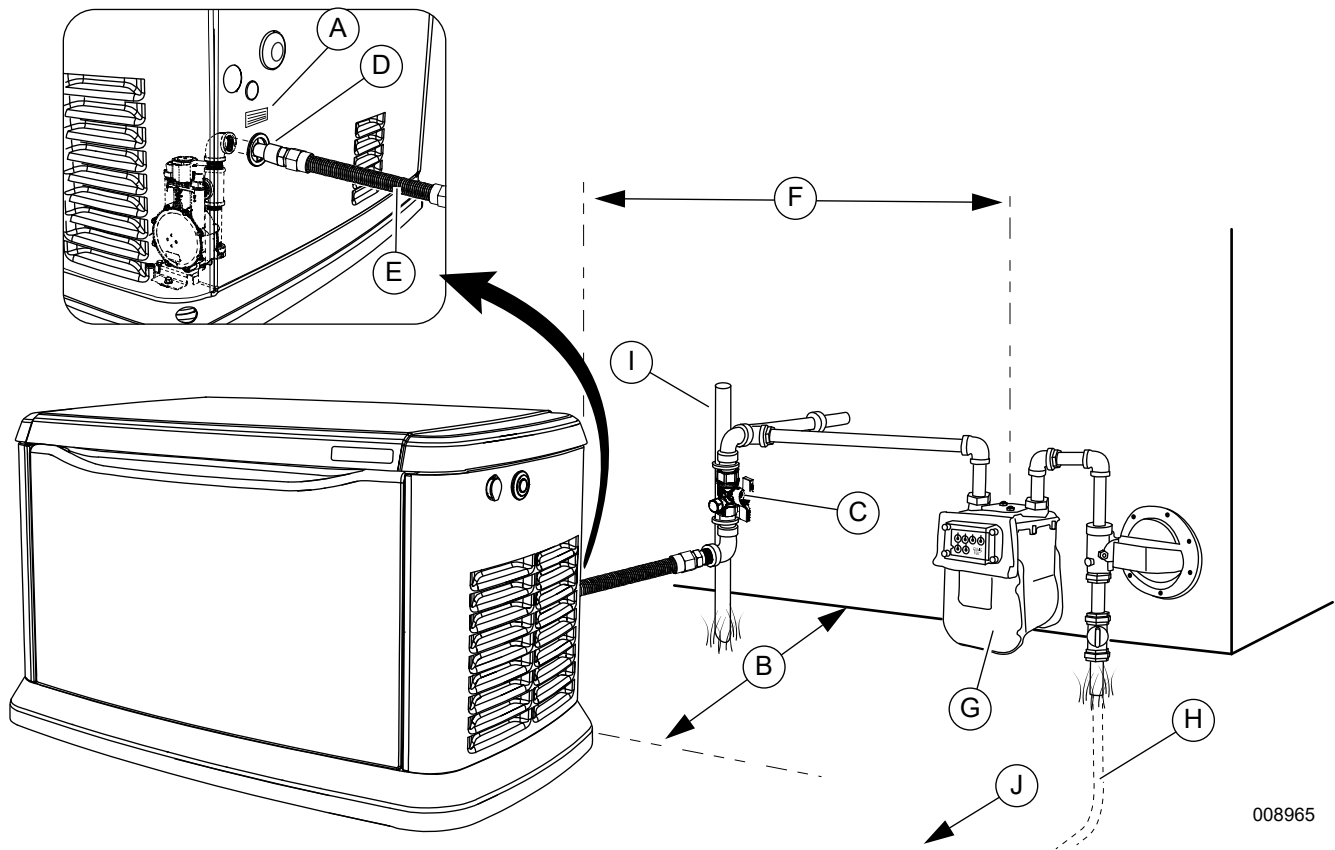

008965

NG Megajoules/h = m ³ /h X 37.26		BTU/h = ft ³ /h X 1000
A	Fuel data decal	
B	Minimum distance from rear obstruction—see Distance Requirements	
C	Manual fuel shutoff valve (pressure port optional) Must be located no more than 1.83 m (6 ft) away from fuel inlet	
D	Pipe fittings	
E	Flexible fuel line	
F	Verify clearance with gas provider	
G	Size gas meter for 100% generator set load plus all appliance loads	
H	For underground installations, verify piping system for code compliance	
I	Reinforcing rod with clamps	
J	To gas main	

Figure 5-7. Natural Gas Installation (typical)

LP Gas (Vapor) Installation (Typical)

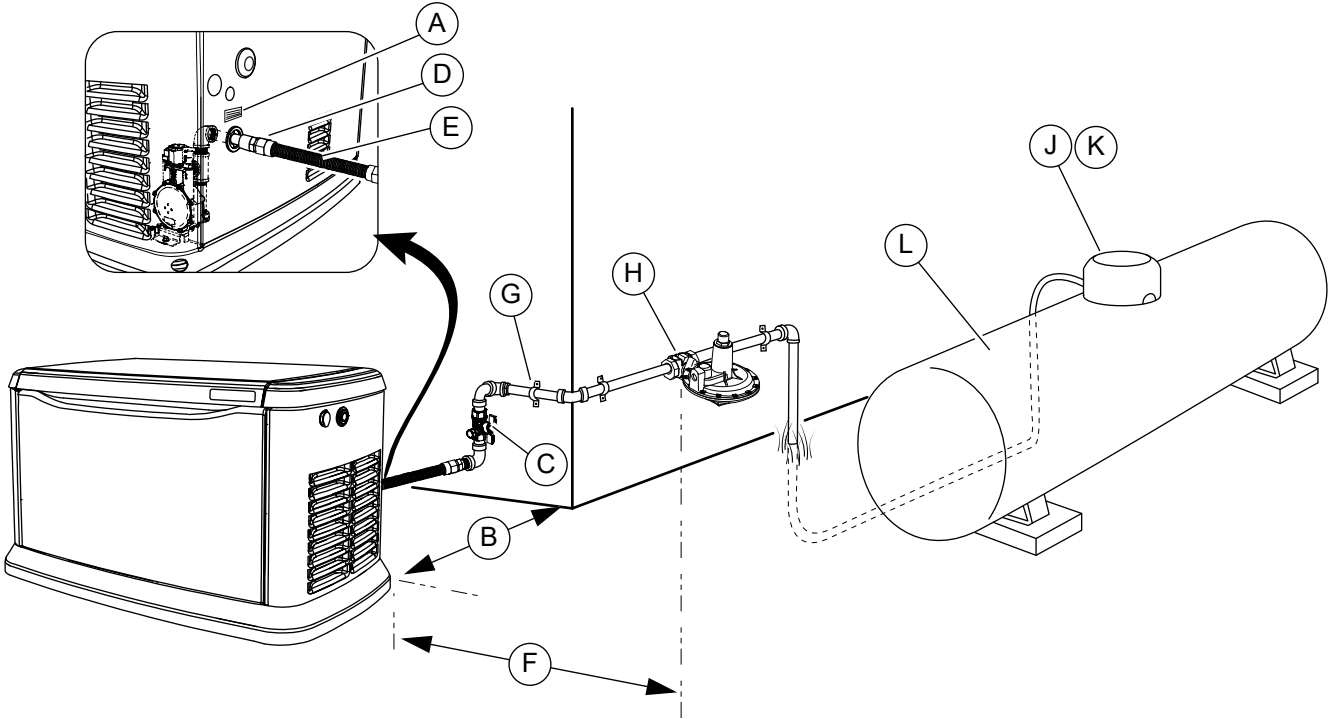

008966

LPG Megajoules/h = m ³ /h X 93.15		BTU/h = ft ³ /h X 2500
A	Fuel data decal	
B	Minimum distance from rear obstruction—see Distance Requirements	
C	Manual fuel shutoff valve (pressure port optional) Must be located no more than 1.83 m (6 ft) away from fuel inlet.	
D	Pipe fittings	
E	Flexible fuel line	
F	Verify minimum distance requirements for regulator vent according to local gas codes.	
G	Clamp	
H	Secondary fuel pressure regulator	
J	Manual fuel shutoff valve	
K	Primary fuel pressure regulator	
L	Fuel tank—sized large enough to provide required MJ/BTU for generator set and ALL connected appliance loads. Be sure to correct for weather evaporation.	

Figure 5-8. LP Gas (Vapor) Installation (typical)

This page intentionally left blank.

Section 6: Electrical Connections

Generator Set Connections



Installation must comply with all national and local electrical building codes.

ISO000218

See **Figure 6-1**. The electrical wiring enclosure is located behind an access panel on the intake end of the unit. Remove intake side panel as directed in **Intake Side Panel Removal**, and then remove access panel with a 4 mm hex key. Connect wires according to diagram and tables.

1. Remove main AC/control wiring knock-out plugs from back of generator set.
2. Using the appropriate wiring hole(s), install conduit and main AC and control wires between generator set and transfer switch.
3. Close any unused hole with a NEMA 3R or IP44 rated plug (field-supplied).

NOTE: All conductors are to be rated for minimum 300V. Control system interconnections may consist of N1, N2, T1, T2, and leads 23 and 194. All of the generator set control wiring circuits are Class 1 remote control or signaling circuits. Class 1 circuits are required to be installed in accordance with Part 1 of NEC Article 300 and with a NEC recognized Chapter 3 wiring method. Use of low voltage cables for generator set control circuit wiring is prohibited. Recommended wire gauge sizes for this wiring depends on wire length, as recommended in **Table 6-3**.

Exception: Conductors of AC and DC circuits, rated 1,000 volts nominal or less, may be permitted to occupy the same equipment, cable, or conduit. All conductors shall have an insulation rating equal to at least the maximum circuit voltage applied to any conductor within the equipment, cable, or conduit. Verify this exception complies with national and local electrical building codes.

4. See **Figure 6-1**. Strip insulation from wire ends. Do not remove excessive insulation. Route sense wires through supplied wire tie (C1), and connect to sense wire terminal block (B). Push down on spring loaded connection point with a flat head screwdriver, insert wire, and release.
5. Using the same process, route control wires through second supplied wire tie (C2), and connect to control wire terminal block (A).
6. Tighten wire ties and clip excess length when all wires are securely connected to correct terminals.

NOTE: Only bare wire should be inserted into each terminal. Do not insert any wire insulation into terminals.

NOTE: Damage caused by mis-wiring of the interconnect wires is not warrantable.

Control Wiring

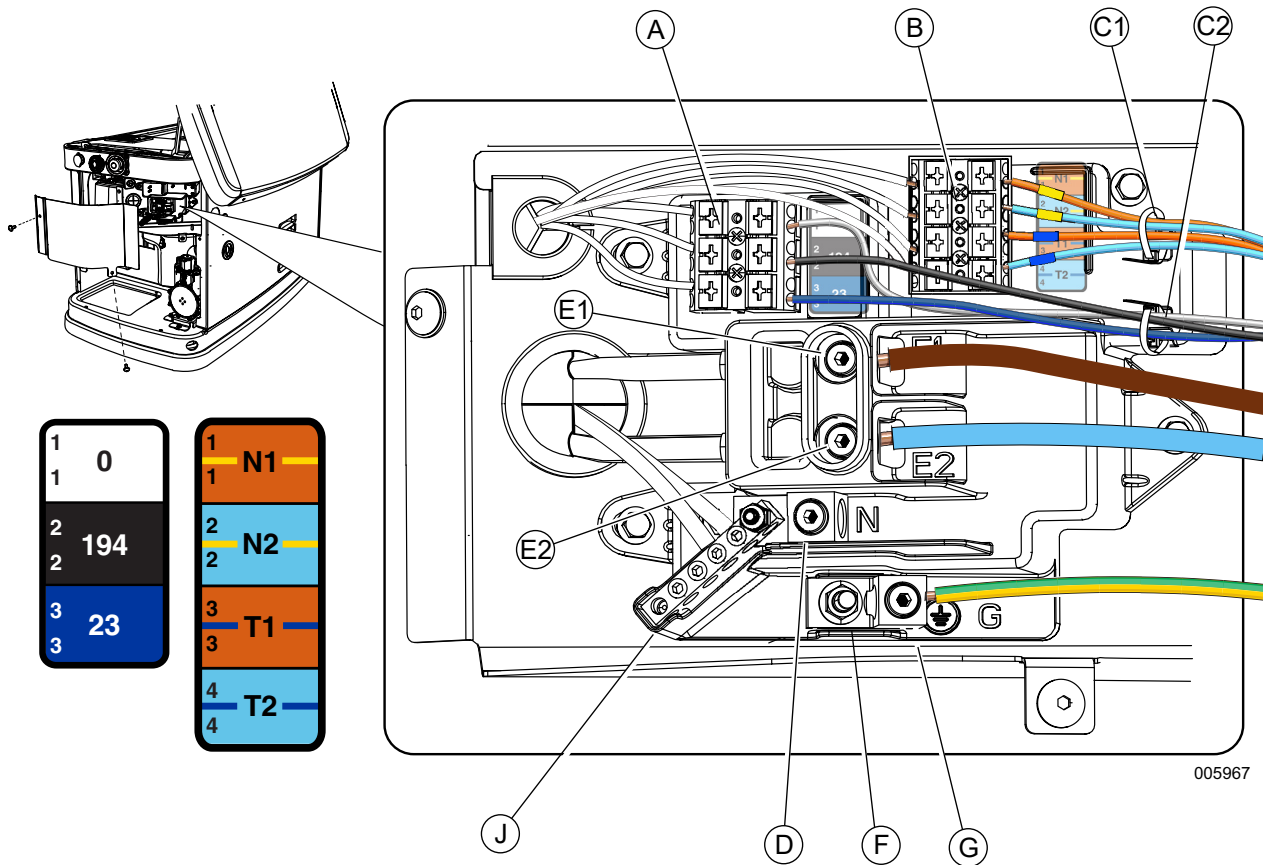

Figure 6-1. Electrical Wiring Connections

Table 6-1. Electrical Wiring Connection Points

ID	Description	ID	Description	ID	Description	ID	Description
A	Control wire terminal block	C2	Wire tie for control wires	E2	Neutral lug	J	Alternator winding junction
B	Sense wire terminal block	D	No service connections	F	Ground stud	—	—
C1	Wire tie for sense wires	E1	Power lug E1	G	Protective earth (PE) ground lug	—	—

Table 6-2. Customer Wiring Connections

Terminal Numbering Decal	Wire Numbers
ORANGE / YELLOW TAG	N1 - Fused 220-230-240 VAC, 6A — Sensing for mains power dropout and pickup
LIGHT BLUE / YELLOW TAG	N2 - Neutral for N1
ORANGE / DARK BLUE TAG *	T1 - Fused 220-230-240 VAC, 6A for battery charger. NOTE: Circuit must be backed up to power the generator controller at all times and keep the battery charged.
LIGHT BLUE / DARK BLUE TAG *	T2 - Neutral for T1
WHITE **	0 - DC (-) Common ground wire
BLACK	194 - DC (+) 12 VDC for transfer controls
BLUE	23 - DC (-) Transfer control signal wire

Table 6-3. Control Wire Recommended Length and Size (Copper conductors only)

Maximum Wire Length	Recommended Wire Size
0.3–35 m (1–115 ft)	No. 18 AWG
35–56 m (115–185 ft)	No. 16 AWG
56–89 m (185–295 ft)	No. 14 AWG
89–140 m (295–460 ft)	No. 12 AWG

* Must be connected to keep battery charged and provide power to control panel whether unit is running or not.

** Required if generator set is paired with Generac Smart Power management transfer switch.

Table 6-4. Ground and Neutral Connections (Copper or Aluminum Conductors)

See national and/or local codes to verify correct wire sizes.				
No.	Description	Recommended Wire Size	Tool Size	Torque Spec
1	Power wire (mains) terminal	2/0 to 8 AWG	3/16 in hex key	13.56 Nm (120 in-lb)
2	Neutral lug terminal	2/0 to 8 AWG	3/16 in hex key	13.56 Nm (120 in-lb)
3	PE ground lug terminal	2/0 to 8 AWG	3/16 in hex key	13.56 Nm (120 in-lb)
4	Alternator winding junction bar	—	1/8 in hex key	2.82 Nm (25 in-lb)

Main AC Wiring

NOTE: Main AC wiring must be in accordance with local jurisdiction and codes.

NOTE: The generator set lugs are rated at 75 °C (167 °F) (copper or aluminum).

- Strip insulation off wire ends. Do not remove excess insulation.
- See [Figure 6-1](#). Loosen lugs at neutral (E2), PE ground (G), and power wire (mains) terminal (E1).
- Connect ground wire to PE ground lug (G). Tighten to required specification. See [Table 6-4](#).
- Connect neutral wire to neutral lug (E2). Tighten to required specification. See [Table 6-4](#).
- Insert power wire into power lug (E1). Tighten to required specification.
- Verify factory-installed ground array and alternator winding junction are correctly tightened to 2.82 Nm (25 in-lb).

NOTE: Tighten all wiring lugs, bus bars, and connection points to required torque specifications.

Conductors of AC and DC circuits, rated 1,000 volts nominal or less, may be permitted to occupy the same equipment, cable, or conduit. All conductors shall have an insulation rating equal to at least the maximum circuit voltage applied to any conductor within the equipment, cable, or conduit. Verify this installation complies with national and local electrical building codes.

Common Alarm Relay (Option)

Alarms relating to generator set and engine performance appear on the controller and in the Mobile Link Wi-Fi app (if used). The controller is equipped with a common alarm relay providing contacts for an optional customer-supplied external alarm indicator.

The common alarm relay is normally open until an alarm occurs, triggering relay to close contacts.

Terminals for the common alarm relay are provided in the wiring harness near the controller plug (Wires 209 and 210).

Contact rating is for resistive load only:

Contact rating	200 mA at 12 VDC
----------------	------------------

Battery Requirements

12 volts, Group 26R Wet Cell 540CCA minimum, or Group 35 AGM 650CCA minimum.

NOTE: Do not use external battery chargers.

Battery Installation



Batteries contain sulfuric acid and can cause severe chemical burns. Wear protective gear when working with batteries.

ISO000138a



Batteries emit explosive gases while charging. Keep fire and spark away. Wear protective gear when working with batteries.

ISO000137a



Disconnect battery ground terminal before working on battery or battery wires.

ISO000164



Wear full eye protection and protective clothing.

ISO000537



Wear rubber gloves and boots when working with batteries.

ISO000536



Strictly observe the following precautions when working on batteries.

ISO000535

- Do not place tools or metallic objects on top of battery.
- Remove all jewelry, including watches, rings, and other metal objects.
- Use tools with insulated handles.
- If electrolyte contacts skin, wash it off immediately with water.
- If electrolyte contacts eyes, thoroughly flush with water immediately and seek medical attention.
- Wash down spilled electrolyte with an acid neutralizing agent. A common practice is to use a solution of 454g (1 lb) bicarbonate of soda to 3.8 L (1 gal) of water. Add bicarbonate of soda solution until evidence of reaction (foaming) has ceased. Flush resulting liquid with water and dry area completely.
- DO NOT smoke when near battery.
- DO NOT cause flame or spark in battery area.
- Discharge static electricity from the body before touching battery by first touching a grounded metal surface.
- **(Unsealed batteries only):** Fill battery with correct electrolyte fluid if necessary.
- Fully charge battery before installing.

Complete the following steps before installing and connecting battery:

1. Verify generator set is OFF.
2. Turn off mains power supply to transfer switch using the means provided (such as a main line utility breaker).
3. Remove 7.5A fuse from the generator set control panel.

Connecting Battery

See [Figure 6-2](#). Battery cables (A, B) were factory connected at the generator set.

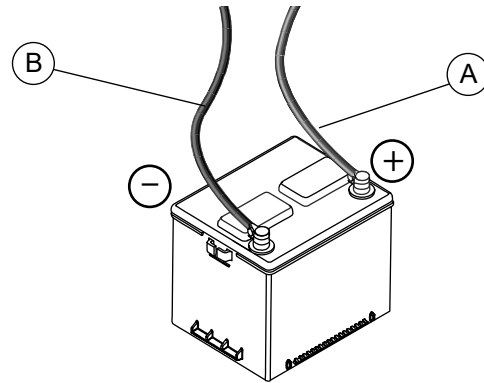

001832

Figure 6-2. Battery Cable Connections

Proceed as follows to connect battery cables:



Always connect positive battery cable first, then the negative battery cable, when installing the battery.

ISO000133

1. Connect red positive battery cable (A: from starter contactor) to positive battery post. Tighten to 8 Nm (70 in-lb).
2. Connect black negative battery cable (B: from frame ground) to negative battery post. Tighten to 8 Nm (70 in-lb).
3. Install red battery post cover (shipped with loose parts).

NOTE: Dielectric grease should be used on battery posts to aid in prevention of corrosion.

NOTE: Damage will result if battery connections are made in reverse.

NOTE: In areas where temperatures fall below -18 °C (0 °F), a pad type battery warmer should be installed to aid in cold climate starting. This is available as part of a cold weather kit offered through an IASD.

A battery warmer is not necessary for AGM-style batteries.

Battery Disposal



Always recycle batteries at an official recycling center in accordance with all local laws and regulations.

ISO000228

Always recycle batteries in accordance with local laws and regulations. Contact your local solid waste collection site or recycling facility to obtain information on local recycling processes. For more information on battery recycling, visit the Battery Council International website at: <http://batteryCouncil.org>

This page intentionally left blank.

Section 7: Control Panel Startup / Testing

Control Panel Interface

See [Figure 7-1](#). The control panel interface (A) is located under the enclosure lid. Verify both left and right side locks are unlocked before attempting to lift enclosure lid. Open enclosure lid as directed in [Opening The Lid](#).

The 7.5A fuse is located beneath the rubber cover (B) to the right of the control panel.

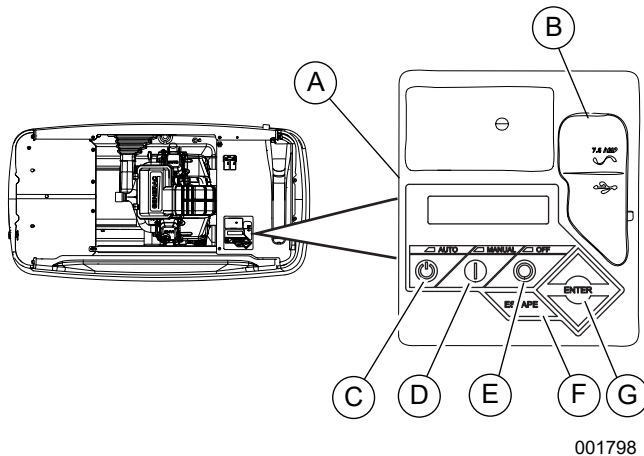

Figure 7-1. Generator Set Control Panel

Using the Control Panel Interface

See [Figure 7-1](#) for button locations.

Button	Description of Operation
AUTO (C)	Activates fully automatic system operation. Allows unit to automatically start and exercise generator set according to exercise timer (see Setting The Exercise Timer). Green LED flashes when generator set is running as a result of a mains power loss.
MANUAL (D)	Cranks and starts generator set. Transfer to standby power will not occur unless there is a mains power failure. Blue LED illuminates when generator set is running in manual mode. LED flashes when generator set is running in manual mode and mains power is lost.
OFF (E)	Shuts down engine and prevents automatic operation of unit.
ESCAPE (F)	Serves as an exit or “go back” function while navigating control panel menus.
ENTER (G)	When pressed, indicates acceptance of a selected setting or navigational menu option.

Control Panel Setup

Activation

To activate the generator set, go to www.activate-gen.com and follow the instructions.

Activation is a simple, one-time process. The generator set will not prompt to activate again once the unit is activated, even if the generator set battery, fuse, and battery charge circuit (T1/T2) are disconnected.

NOTE: The generator set must be connected to the home Wi-Fi network for automatic authentication to be completed successfully. See Wi-Fi manual for more information.

NOTE: If home Wi-Fi network is not available, follow instructions on www.activategen.com.

Proceed as follows after activating generator set on-line:

1. The display interface will launch Install Wizard upon first power-up of the generator set.
2. Follow on-screen instructions on the generator set along with Quick Start Guide supplied with the unit to connect generator set to home Wi-Fi network.
3. Wait for on-line authentication of generator set activation through connected home Wi-Fi network.
4. Follow on-screen instructions to complete the Install Wizard.

NOTE: See [Figure 7-2](#). If generator set screen shows message shown below, press ESC and then ENTER to reset to Install Wizard.

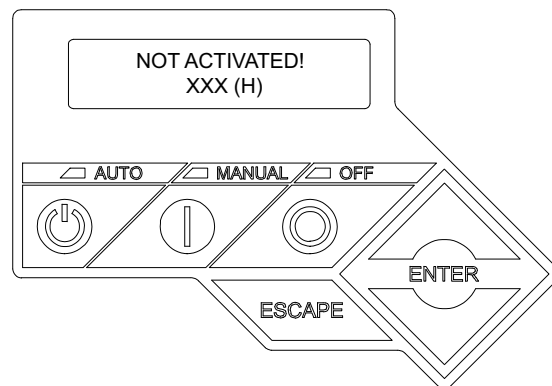
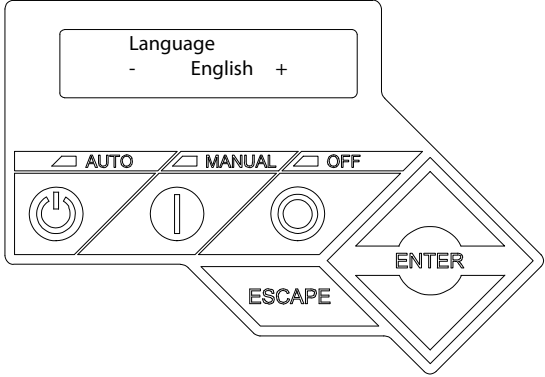
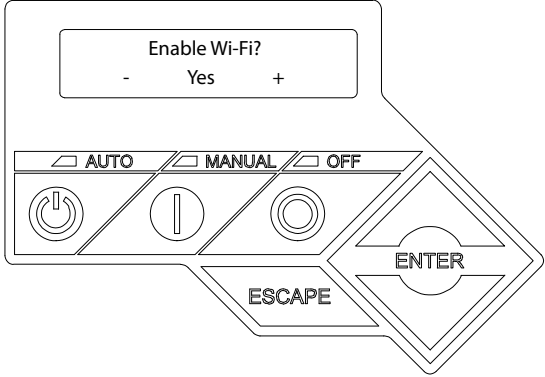
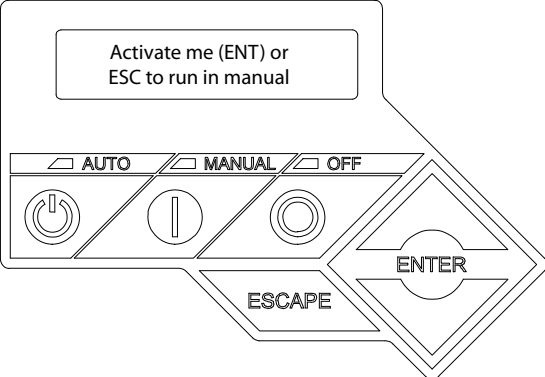
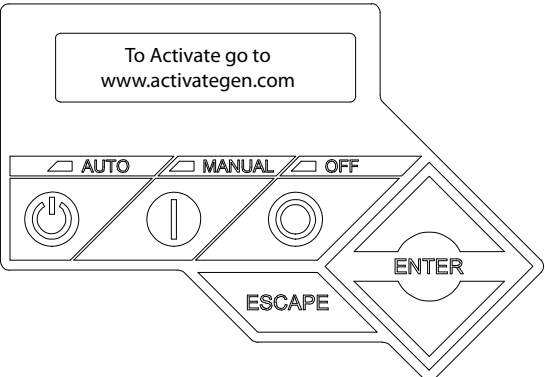
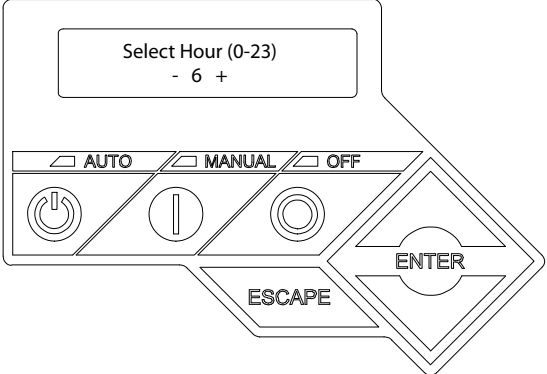

Figure 7-2. Not Activated Screen

NOTE: Generator set can only be placed in AUTO mode after completing activation process.

IMPORTANT NOTE: Fuel selector knob must be set to the correct fuel for generator set to function correctly.

Display Reads		Troubleshooting
 <p>Language - English +</p> <p>AUTO MANUAL OFF</p> <p>ENTER</p> <p>ESCAPE</p> <p>002227</p>	<p>Use arrow keys to scroll to desired language. Press ENTER to select.</p>	<p>Language can be changed later using EDIT menu.</p>
 <p>Enable Wi-Fi? - Yes +</p> <p>AUTO MANUAL OFF</p> <p>ENTER</p> <p>ESCAPE</p> <p>004498</p>	<p>Use arrow keys to either enable or disable Wi-Fi. If YES, see Wi-Fi manual. If NO, continue.</p>	
 <p>Activate me (ENT) or ESC to run in manual</p> <p>AUTO MANUAL OFF</p> <p>ENTER</p> <p>ESCAPE</p> <p>002228</p>	<p>Press ENTER to begin the activation process.</p>	<p>If ESCAPE is pressed instead of ENTER, generator set will only run in manual mode (for test purposes), and NOT ACTIVATED will be displayed. Press ESC and then ENTER to reset Install Wizard</p>
 <p>To Activate go to www.activategen.com</p> <p>AUTO MANUAL OFF</p> <p>ENTER</p> <p>ESCAPE</p> <p>002229</p>	<p>If unit has not been activated, go to www.activategen.com. If unit has been activated, press ESC and then ENTER.</p>	

Display Reads		Troubleshooting
 <p>002231</p>	<p>Activation is complete when this screen is displayed. Follow controller prompts to complete installation.</p>	

Cold Smart Start

The Cold Smart Start feature is factory-enabled, and can be disabled in the EDIT menu. Generator set will monitor ambient temperature and adjust its warm-up delay accordingly when Cold Smart Start is enabled. If ambient temperature is below a fixed temperature upon startup in AUTO mode (per the chart below), generator set will warm up for 30 seconds, allowing engine to warm before load is applied. If ambient temperature is at or above fixed temperature, generator set will start up with normal warm-up delay of six seconds. See Cold Smart Start section of owner's manual.

Cold Smart Start Set Point = 10 °C (50 °F)

Setting The Exercise Timer

This generator set is equipped with a configurable exercise timer. There are two settings for the exercise timer:

- **Day/Time:** Generator set will start and exercise for the period defined, on day of week and at time of day specified. During this exercise period, unit runs for five to twelve minutes depending on model, and then shuts down.
- **Exercise frequency (how often exercise will take place):** Can be set to Weekly, Biweekly, or Monthly. If Monthly is selected, day of month must be selected from 1–28. Generator set will exercise on that day each month. Transfer of loads to generator set output does not occur during exercise cycle unless mains power is lost.

NOTE: If installer tests generator set prior to installation, press ENTER button to skip setting up exercise timer.

NOTE: The exercise feature will operate only when generator set is placed in AUTO mode, and will not work unless this procedure is performed. If Wi-Fi is **not** enabled, current date/time must be reset every time power is removed from the controller through the 7.5A fuse and T1/T2 circuit and/or battery connections.

NOTE: The exercise timer does not automatically adjust for Daylight Saving Time.

NOTE: When using Wi-Fi module, exercise time will be set at random. Time settings can be changed later. See Wi-Fi manual for details.

Before Initial Startup



Engine damage. Verify proper type and quantity of oil prior to starting engine. Failure to do so could result in engine damage.

ISO000135



Wear ear protection.

ISO000107



Wear full eye protection and protective clothing.

ISO000537

NOTE: The unit has been run and tested at the factory prior to being shipped and does not require any type of break-in.

NOTE: The unit comes from the factory filled with 5W-30 weight organic oil. Verify oil level and add the appropriate viscosity and amount of oil if necessary.

Install Wizard

See [Figure 7-3](#) and [Figure 7-4](#). The Install Wizard immediately appears upon startup. It allows the user to input generator set settings.

NOTE: Install Wizard will start every time AC and DC power are removed and reapplied to the generator set.

Interconnect System Self Test Feature

This controller goes through a system self test at startup, which checks for mains voltage on DC circuits. This check prevents damage if installer incorrectly connected AC mains power sense wires into the DC terminal block. The controller will display a warning message and lock out the generator set if mains voltage is detected at the DC terminal block, preventing damage to the controller. Power to controller must be removed to clear warning.

Mains voltage must be turned on and present at the N1 and N2 terminals inside the generator set control panel for this test to be performed and pass.

NOTE: All appropriate panels must be in place during any operation of generator set. This includes operation by a servicing technician, while conducting troubleshooting procedures.

Before starting, complete the following:

1. Verify generator set is OFF.
2. Set generator main circuit breaker to OFF (OPEN).
3. Turn off all breakers to be powered by generator set.
4. Check engine crankcase oil level and, if necessary, fill to the oil dipstick FULL mark with recommended oil. Do not overfill.
5. Inspect fuel supply. Gaseous fuel lines must have been correctly purged and leak tested in accordance with applicable fuel-gas codes. All fuel shut-off valves in the fuel supply lines must be open.

During initial startup only, generator set may exceed normal number of start attempts and experience an "OVER-CRANK" fault. This is due to accumulated air in fuel system during installation. Reset control board by pressing OFF mode button and ENTER button, and start up to two more times if necessary. Contact an IASD for assistance if unit fails to start.

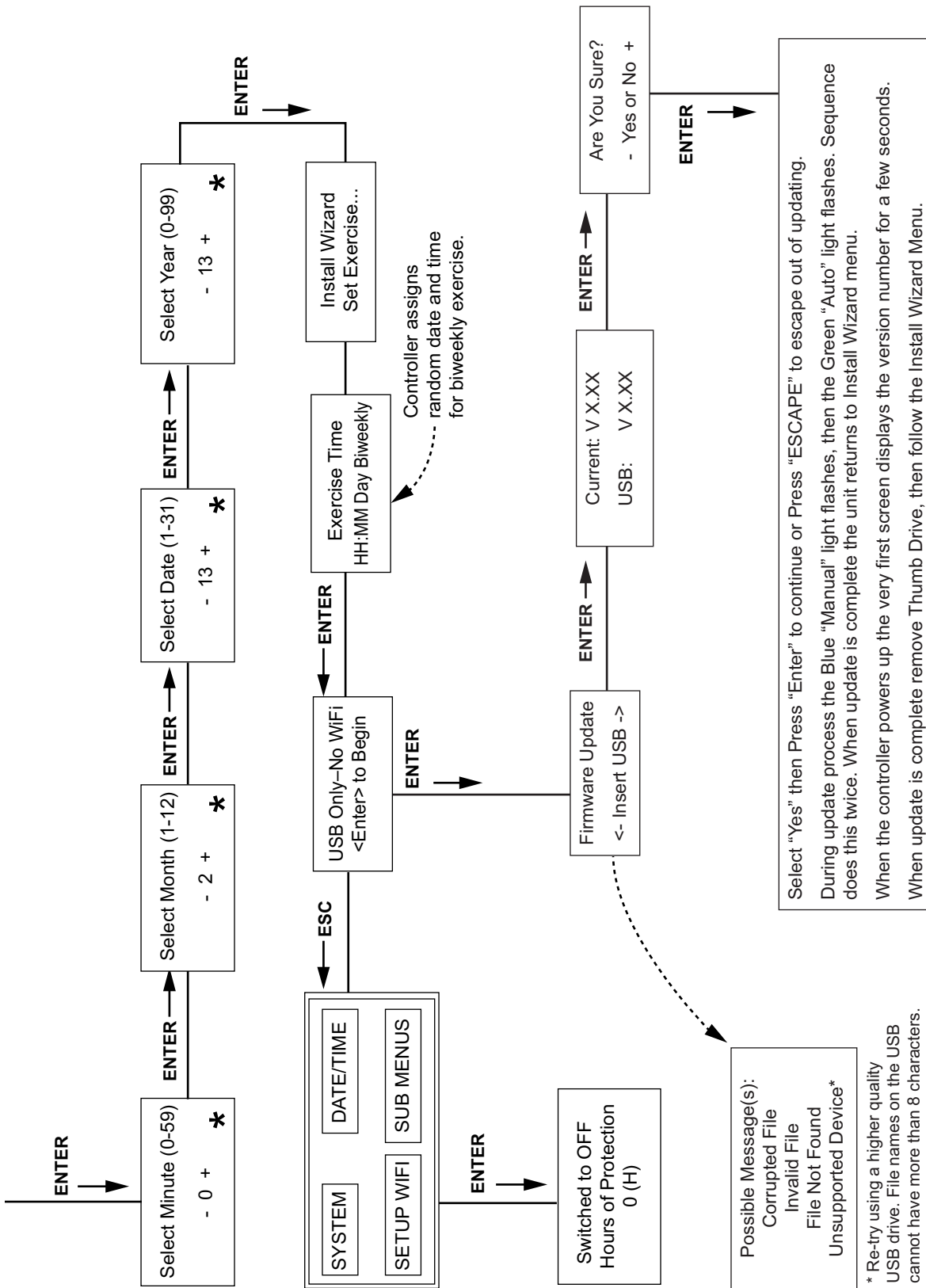

006669

Figure 7-4. Install Wizard Menu Map

Checking Manual Transfer Switch Operation



Do not manually transfer under load. Disconnect transfer switch from all power sources prior to manual transfer.

ISO000132

See Manual Transfer Operation section of owner's manual for procedures.

Electrical Checks



High voltage is present at transfer switch and terminals.

ISO000129



Wear ear protection.

ISO000107



Wear full eye protection and protective clothing.

ISO000537

Proceed as follows to complete electrical checks:

1. Verify generator set is OFF.
2. Set MLCB (generator disconnect) to OFF (OPEN).
3. Turn off all circuit breakers/electrical loads to be powered by generator set.
4. Turn on mains power supply to transfer switch using the means provided (such as a main line utility breaker).
5. Use a calibrated AC voltmeter to verify mains power source voltage across transfer switch terminals N1 and N2 at the generator set. Nominal line-to-line voltage should be output voltage selected during installation (e.g. 220 VAC). If voltage is incorrect, verify AC output and wiring from mains power source to N1 and N2 lugs at transfer switch.
6. Turn off mains power supply to transfer switch when certain mains power supply voltage is compatible with transfer switch and load circuit ratings.
7. Verify wiring from generator set E1 and E2 to transfer switch E1 and E2.

8. Push MANUAL button on generator set control panel. Engine will crank and start. Record cranking fuel pressure: _____.
9. Allow engine warm up for approximately five minutes for internal temperatures to stabilize. Then set MLCB (generator disconnect) to ON (CLOSED). Record running fuel pressure: _____.
10. Connect a calibrated AC voltmeter and a calibrated frequency meter across transfer switch terminal lugs where E1 and E2 wires are terminated. Voltage should be output voltage selected during installation $\pm 2V$ (e.g. 218-222 VAC) at a frequency of 49.5–50.5 Hz. If voltage is incorrect, verify MLCB (generator disconnect) is ON (CLOSED) and verify AC output and frequency (Hertz or Hz) at the MLCB. Verify wiring from generator set to E1 and E2 lugs at transfer switch.
11. Verify wiring from generator set to E1 and E2 at transfer switch.
12. Set MLCB (generator disconnect) to OFF (OPEN).
13. Press OFF mode button on control panel. Engine will shut down.

IMPORTANT NOTE: Do not proceed until generator AC voltage and frequency are correct and within stated limits.

Generator Set Tests Under Load



Do not manually transfer under load. Disconnect transfer switch from all power sources prior to manual transfer.

ISO000132

Proceed as follows to test generator set with electrical loads applied:

1. Verify generator set is in OFF mode.
2. Set MLCB (generator disconnect) to OFF (OPEN).
3. Turn off all breakers/electrical loads to be powered by generator set.
4. Turn off mains power supply to transfer switch using the means provided (such as a main line utility breaker).
5. Manually actuate transfer switch to STANDBY position. See transfer switch operator's manual for correct procedure.
6. Press MANUAL mode button on control panel to crank and start engine.
7. Allow engine to stabilize and warm up for a few minutes.
8. Set MLCB (generator disconnect) to ON (CLOSED). Loads are now powered by standby generator set.

9. Turn on circuit breakers/electrical loads powered by generator set one by one.
10. Connect a calibrated AC voltmeter and a calibrated frequency meter across terminal lugs E1 and E2. Voltage should be the approximate output voltage selected during installation, and frequency should be approximately 50 Hz. If voltage and frequency are rapidly dropping as loads are applied, generator set may be overloading, or there may be a fuel issue. Verify amperage value of loads and/or fuel pressure.
11. Allow generator set to run at full rated load for 20–30 minutes. Listen for unusual noises, vibration, or other indications of abnormal operation. Inspect for oil leaks, evidence of overheating, etc.
12. Verify fuel pressure while under full load. Record loaded fuel pressure: _____.
13. Turn off electrical loads when testing under load is complete.
14. Set MLCB (generator disconnect) to OFF (OPEN).
15. Allow engine to run at no-load for 2–5 minutes.
16. Press OFF button on control panel. The engine will shut down.

NOTE: If fuel pressure under full load is below minimum operating pressure guideline, generator set may not function correctly. The fuel pressure gauge needle should remain steady while testing. A fluctuating fuel pressure gauge needle indicates gas piping may be undersized or restricted. It may also indicate a step-down gas regulator is too small, or too close to the unit.

Checking Automatic Operation

Proceed as follows to check the system for correct automatic operation:

1. Verify generator set is OFF.
2. Install front cover of transfer switch.
3. Turn on mains power supply to transfer switch using the means provided (such as a main line utility breaker).

NOTE: Transfer switch will transfer to mains position.

4. Set MLCB (generator disconnect) to ON (CLOSED).
5. Press generator set AUTO button. System is now ready for automatic operation.
6. Turn off mains power supply to transfer switch.

The generator set is ready for automatic operation. Engine will crank and start when mains source power is turned off after a five second delay (factory default setting). After starting, transfer switch will connect load circuits to standby side after a 5 or 30 second delay (dealer programmable). See **Cold Smart Start**. Allow system to operate through entire automatic sequence of operation.

With generator set running and loads powered by generator set AC output, turn on mains power supply to transfer switch. The following will occur:

- After approximately 15 seconds (dealer programmable), transfer switch will transfer loads to mains power source.
- Approximately one minute after transfer, engine will shut down.

Installation Summary

1. Verify installation has been performed correctly as outlined by the manufacturer and that it meets all applicable laws and codes.
2. Test and verify correct operation of the system as outlined in the appropriate installation and owner's manuals.
3. Educate end-user on correct operation, maintenance, and service call procedures.

Shutting Generator Set Down While Under Load Or During A Mains Power (Utility) Outage



Automatic start-up. Disconnect mains power and render the equipment inoperable before attempting repairs or maintenance.

ISO000191a

IMPORTANT NOTE: To avoid equipment damage, follow these steps, in order, during mains power outages. Shutdowns may be required during mains power outages to perform routine maintenance or to conserve fuel.

To turn generator OFF:

1. Turn off mains power supply to transfer switch using means provided (such as a main line utility breaker).
2. Set main circuit breaker in distribution panel to OFF (OPEN) to remove all loads from generator set.
3. To shut down generator set:
 - Allow generator set to run for five minutes at no load.
 - After five minutes, use emergency stop button to shut down generator set.
 - Wait 15 minutes to allow internal temperature to stabilize.

NOTE: Failure to follow this procedure may expose user to hot surfaces. See **Hot Surfaces** in Section 1.

4. Open lid and reset emergency stop alarm on control panel.

5. Set MLCB (generator disconnect) on generator set to OFF (OPEN).
6. Remove the 7.5A fuse from control panel.

To turn generator set back ON:

1. Install 7.5A fuse in control panel.
2. Verify MLCB (generator disconnect) is OFF (OPEN).
3. Press AUTO mode button on the control panel.
4. Generator set will start and run. Allow generator set to run and warm up for a few minutes.
5. Set MLCB (generator disconnect) to ON (CLOSED).
6. Close and lock lid.
7. Set main circuit breaker in the distribution panel to ON (CLOSED).
8. Turn on mains power supply to transfer switch using means provided.

The system now operates in automatic mode.

This page intentionally left blank.

Section 8: Troubleshooting

Generator Set Troubleshooting

Problem	Cause	Correction
Engine will not crank	Blown fuse.	Correct short circuit condition by replacing 7.5 amp fuse in generator set control panel. Contact an IASD for assistance if fuse continues to blow.
	Loose, corroded, or faulty battery cables.	Tighten, clean, or replace as necessary.*
	Faulty starter contact.	
	Faulty starter motor.	
	Discharged battery.	Charge or replace battery.
Engine cranks but will not start	No fuel.	Replenish fuel / turn on fuel valve.
	High fuel pressure.	Verify and adjust fuel pressure.
	Fuel selector in wrong position.	Set fuel conversion knob to correct position.
	Faulty fuel solenoid (FS).	Contact an IASD.
	Faulty spark plug(s).	Clean; inspect gap; replace plug(s) as needed.
	Valve clearance out of adjustment.	Reset valve clearance.
Engine starts hard and runs rough	Air cleaner plugged or damaged.	Inspect and clean air cleaner.
	Faulty spark plug(s).	Clean; inspect gap; replace plug(s) as needed.
	Incorrect fuel pressure.	Verify fuel pressure to regulator is 2.49–2.99 kPa (10–12 in water column) for LP gas, and 0.87–1.74 kPa (3.5–7 in water column) for NG.
	Fuel selector in wrong position.	Set fuel conversion valve to correct position.
	Valve(s) out of adjustment.	Adjust valve clearance.
	Internal engine issue.	Contact an IASD.
Unit is set to OFF, but engine continues to run	Controller wired incorrectly.	Contact an IASD.
	Faulty control board.	
No AC output from generator set	MLCB (generator disconnect) is OFF (OPEN).	Reset circuit breaker to ON (CLOSED).
	Generator internal failure.	Contact an IASD.
	Engine may be warming up. See <i>Cold Smart Start</i> .	Check controller screen to verify status.

Problem	Cause	Correction
No transfer to standby after mains power source failure	MLCB is OFF (OPEN).	Reset circuit breaker to ON (CLOSED).
	Faulty transfer switch coil.	Contact an IASD.
	Faulty transfer relay.	
	Transfer relay circuit open.	
	Faulty control logic board.	
	Engine may be warming up. See Cold Smart Start .	Check controller screen to verify status.
Unit consumes large amounts of oil	Excessive engine oil.	Adjust oil to correct level.
	Faulty engine breather.	Contact an IASD.
	Incorrect type or viscosity of oil.	See Engine Oil Recommendations in owner's manual.
	Damaged gasket, seal, or hose.	Inspect for oil leaks.
	Restricted air filter.	Replace air filter.
* Contact an IASD or visit https://www.pramac.com/worldwide for assistance.		

Section 9: Quick Reference Guide

Quick Reference Guide

To clear an active alarm, press OFF mode button and then ENTER button on the control panel. Then press AUTO mode button. Contact an IASD if alarm reoccurs.

Active Alarm	LED	Problem	Things to Check	Solution
NONE	FLASHING GREEN	Unit running in AUTO but no power in house.	Check MLCB.	Check MLCB. If it is ON, contact an IASD.
HIGH TEMPERATURE	RED	Unit shuts down during operation.	Check LEDs / screen for alarms.	Inspect ventilation around generator set, intake, exhaust, and rear of generator set. If no obstructions are present, contact an IASD.
OVERLOAD REMOVE LOAD	RED	Unit shuts down during operation.	Check LEDs / screen for alarms.	Clear alarm and remove household loads from generator set. Put in AUTO and start.
RPM SENSE LOSS	RED	Unit was running and shut down, attempts to restart.	Check LEDs / screen for alarms.	Clear alarm and remove household loads from generator set. Put into AUTO and start. If generator set does not start, contact an IASD.
NOT ACTIVATED	NONE	Unit will not start in AUTO with mains power loss.	Verify if screen says unit not activated.	See Activation section in owner's manual.
NONE	GREEN	Unit will not start in AUTO with mains power loss.	Check screen for start delay countdown.	If startup delay is greater than expected, contact an IASD to adjust from 2 to 1,500 seconds.
LOW OIL PRESSURE	RED	Unit will not start in AUTO with mains power loss.	Check LEDs / screen for alarms.	Check oil level and add oil as needed. If oil level is correct, contact an IASD.
RPM SENSE LOSS	RED	Unit will not start in AUTO with mains power loss.	Check LEDs / screen for alarms.	Clear alarm. Using control panel, check battery by navigating to BATTERY MENU option from MAIN MENU. If battery condition displays GOOD, contact an IASD. If control panel displays CHECK BATTERY, replace battery.
OVERCRANK	RED	Unit will not start in AUTO with mains power loss.	Check LEDs / screen for alarms.	Verify fuel line shutoff valve is ON. Clear alarm. Start unit in MANUAL. If it does not start, or starts and runs rough, contact an IASD.
LOW VOLTS REMOVE LOAD	RED	Unit will not start in AUTO with mains power loss.	Check LEDs / screen for alarms.	Clear alarm and remove household loads from generator set. Put in AUTO and start.
OVERSPEED	RED	Unit will not start in AUTO with mains power loss.	Check LEDs / screen for alarms.	Contact an IASD.
UNDERVOLTAGE	RED	Unit will not start in AUTO with mains power loss.	Check LEDs / screen for alarms.	Contact an IASD.
UNDERSPEED	RED	Unit will not start in AUTO with mains power loss.	Check LEDs / screen for alarms.	Contact an IASD.
STEPPER OVERCURRENT	RED	Unit will not start in AUTO with mains power loss.	Check LEDs / screen for alarms.	Contact an IASD.
MISWIRE	RED	Unit will not start in AUTO with mains power loss.	Check LEDs / screen for alarms.	Contact an IASD.

Active Alarm	LED	Problem	Things to Check	Solution
OVERVOLTAGE	RED	Unit will not start in AUTO with mains power loss.	Check LEDs / screen for alarms.	Contact an IASD.
EMERGENCY STOP	RED	Unit will not start in AUTO with mains power loss.	Check screen for additional information.	Verify emergency stop button is disengaged (pulled out). Clear alarm.
LOW BATTERY	YELLOW	Yellow LED illuminated in any state.	Check screen for additional information.	Clear alarm. Using control panel, check battery by navigating to BATTERY MENU option from MAIN MENU. If battery condition displays GOOD, contact an IASD. If control panel displays CHECK BATTERY, replace battery.
BATTERY PROBLEM	YELLOW	Yellow LED illuminated in any state.	Check screen for additional information.	Contact an IASD.
CHARGER WARNING	YELLOW	Yellow LED illuminated in any state.	Check screen for additional information.	Contact an IASD.
SERVICE A	YELLOW	Yellow LED illuminated in any state.	Check screen for additional information.	Perform SERVICE A maintenance. Press ENTER to clear.
SERVICE B	YELLOW	Yellow LED illuminated in any state.	Check screen for additional information.	Perform SERVICE B maintenance. Press ENTER to clear.
INSPECT BATTERY	YELLOW	Yellow LED illuminated in any state.	Check screen for additional information.	Inspect battery. Press ENTER to clear.

Section 10: Accessories

Performance enhancing accessories are available for air-cooled generator sets.

Accessory	Description
Cold Weather Accessories*— <ul style="list-style-type: none"> • Battery Pad Warmer • Oil Warmer <i>* each sold separately</i>	<ul style="list-style-type: none"> • Recommended in areas where temperatures fall below -18 °C (0 °F). <i>(Not necessary for use with AGM-style batteries)</i> • Recommended in areas where temperatures fall below -18 °C (0 °F).
Scheduled Maintenance Kit	Includes all pieces necessary to perform maintenance on the generator set along with oil recommendations.
Fascia Base Wrap	The fascia base wrap snaps together around the bottom of the new air-cooled generator set. This offers a sleek, contoured appearance as well as offering protection from rodents, reptiles, and insects by covering the lifting holes located in the base. Requires use of the mounting pad shipped with the generator set.
Touch-Up Paint Kit	Very important to maintain the look and integrity of the generator set enclosure. This kit includes touch-up paint and instructions.

NOTE: Contact an IASD or visit <https://www.pramac.com/worldwide> for additional information on accessories and extended warranties.

This page intentionally left blank.

Section 11: Diagrams

Installation Drawing (10000010676—1 of 2)

MOUNTING TO CONCRETE PAD

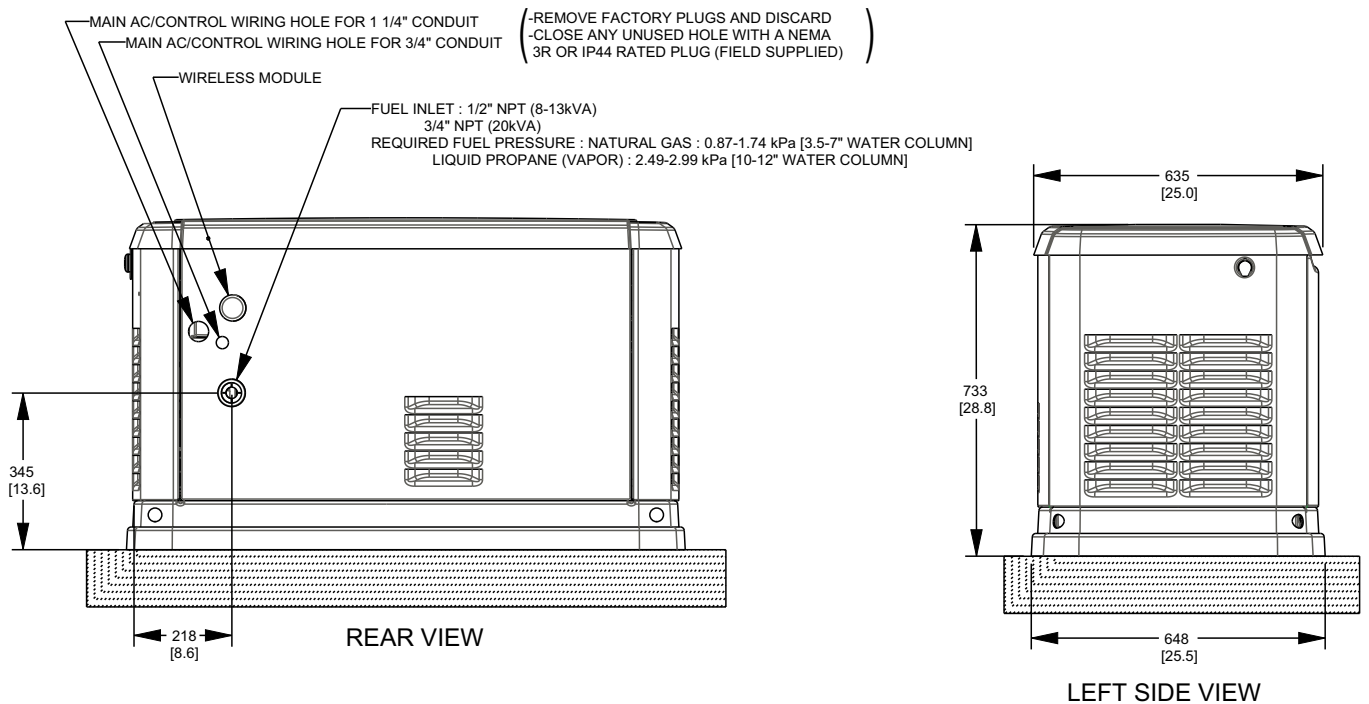
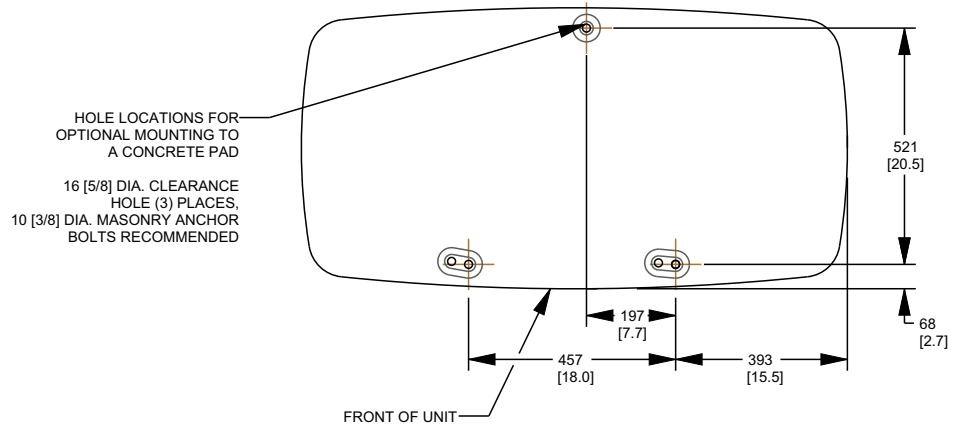

Installation Drawing (10000010676—2 of 2)

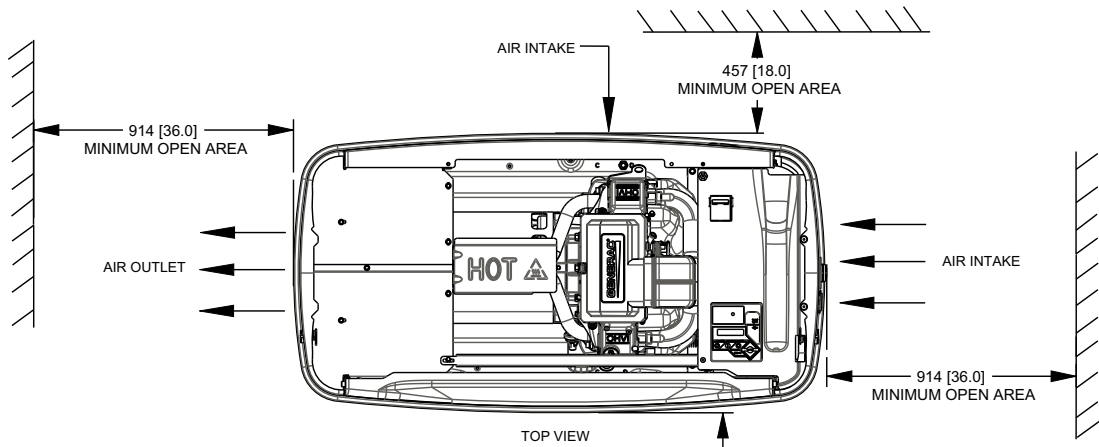

"DO NOT LIFT BY ROOF"

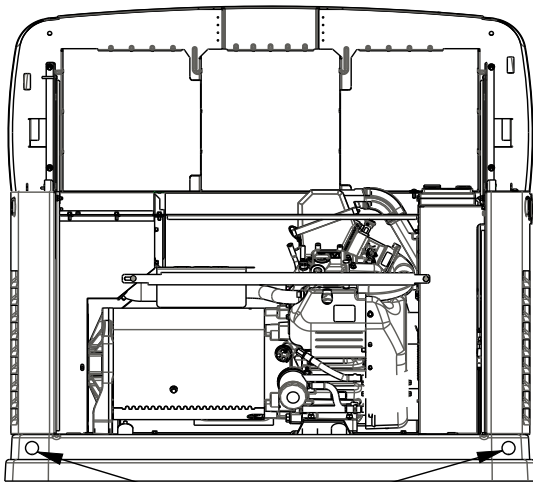

LIFTING HOLES 4 CORNERS: $\varnothing 30$ [$\varnothing 1.2$]
 - MUST BE LIFTED WITH STEEL RODS
 - RECOMMENDED LIFTING ROD SIZE: $\varnothing 25$ [$\varnothing 1.0$]

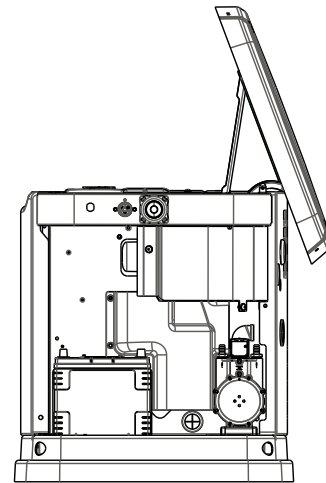
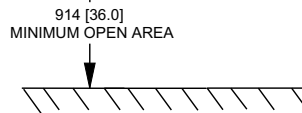

RIGHT VIEW
INTAKE PANEL REMOVED

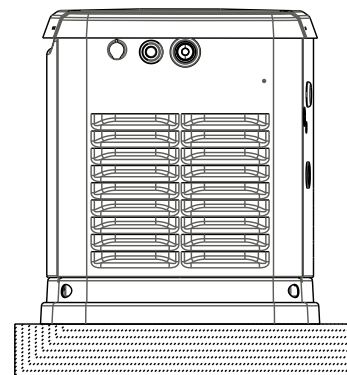
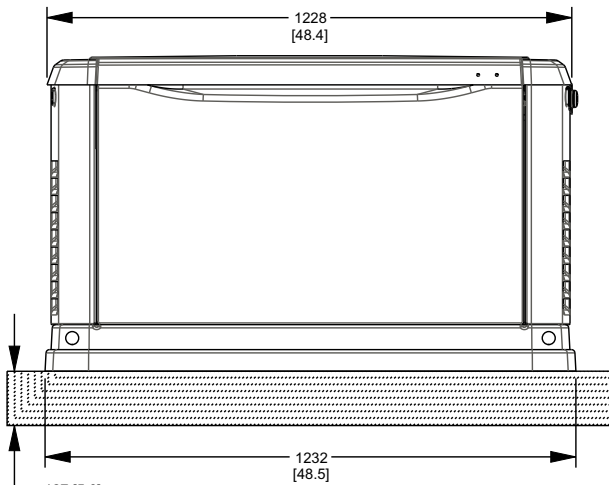

RIGHT SIDE VIEW

Wiring Diagram (1000007481—1 of 6)

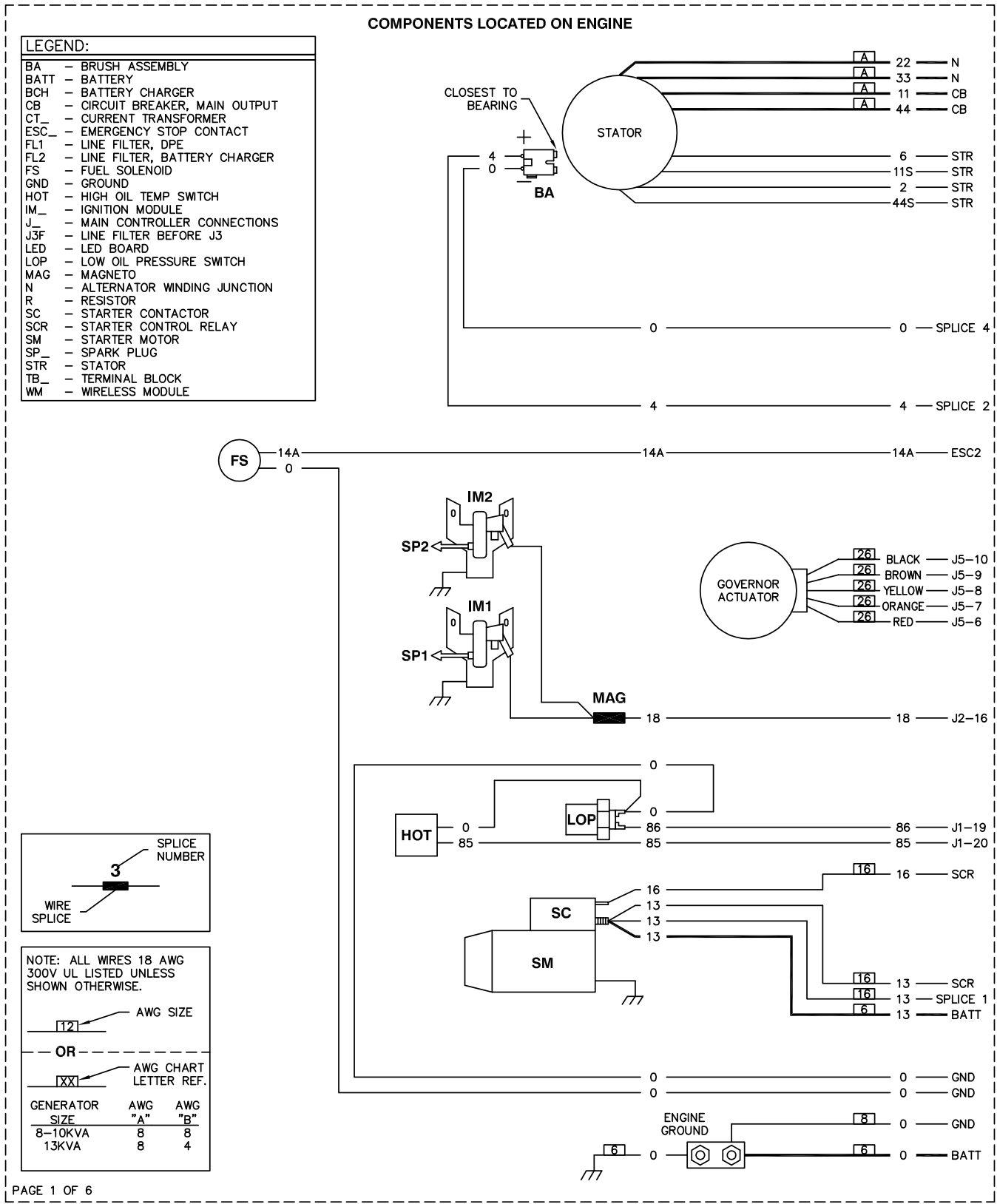

Wiring Diagram (1000007481—2 of 6)

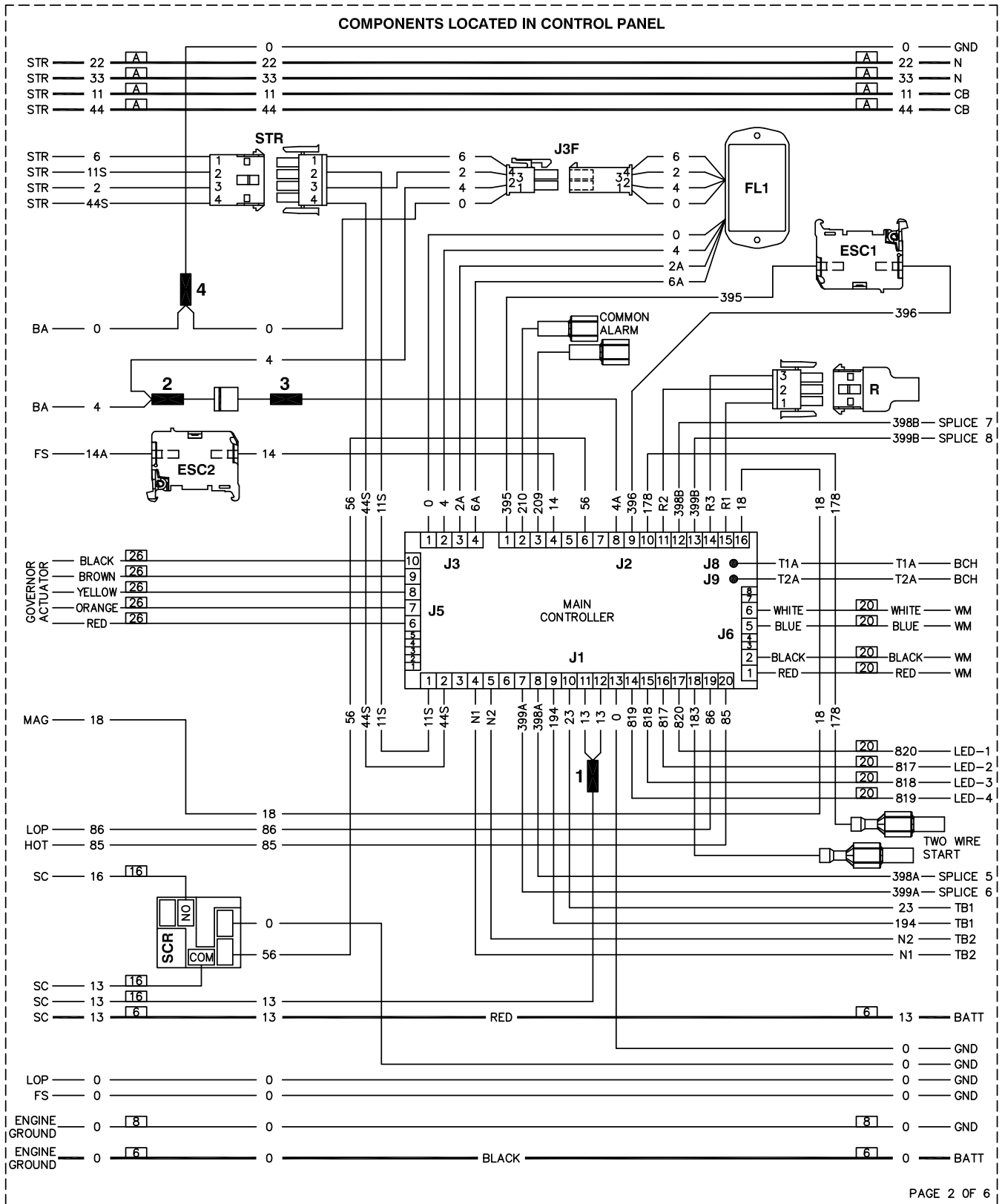

Wiring Diagram (1000007481—3 of 6)

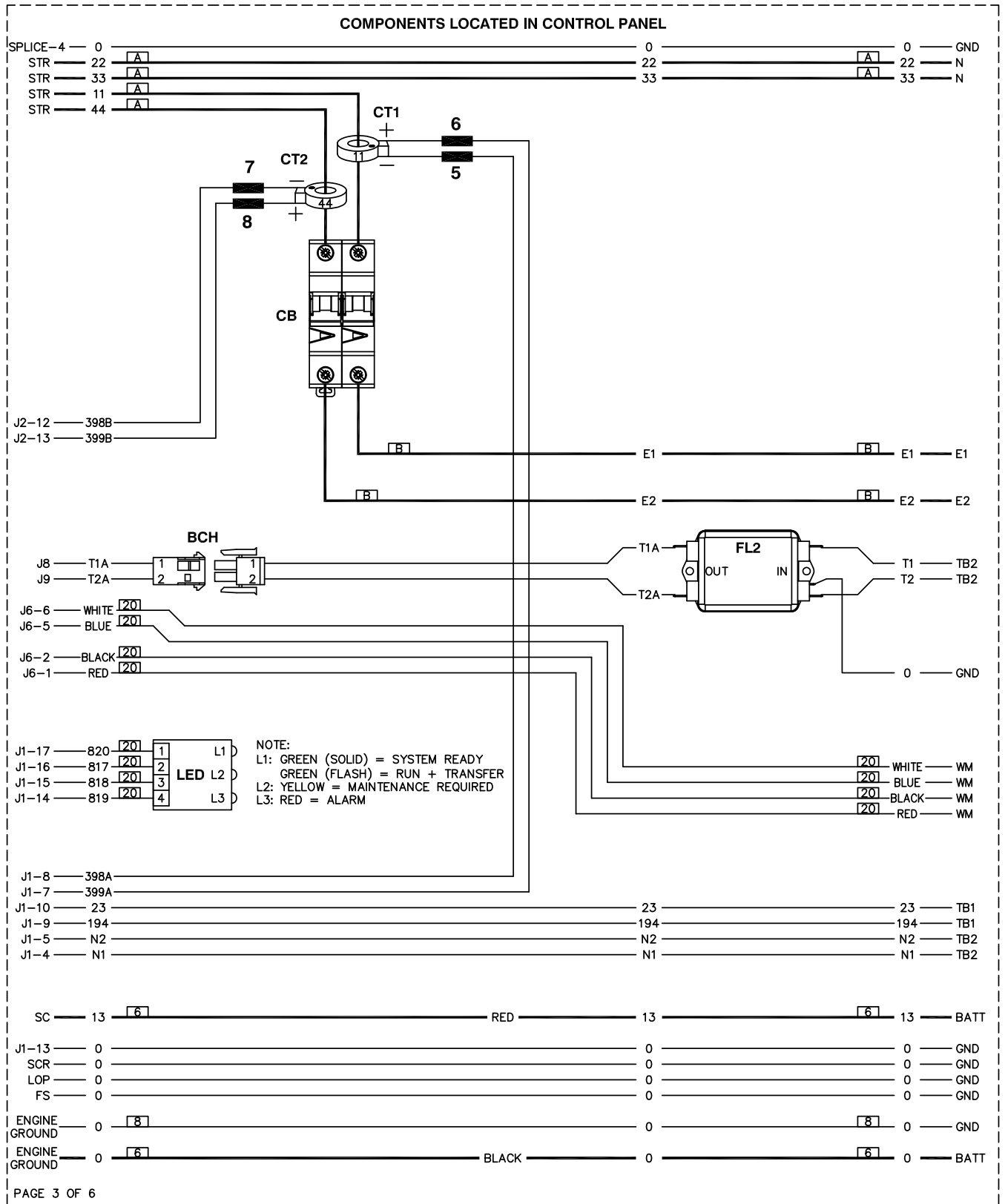

Wiring Diagram (1000007481—4 of 6)

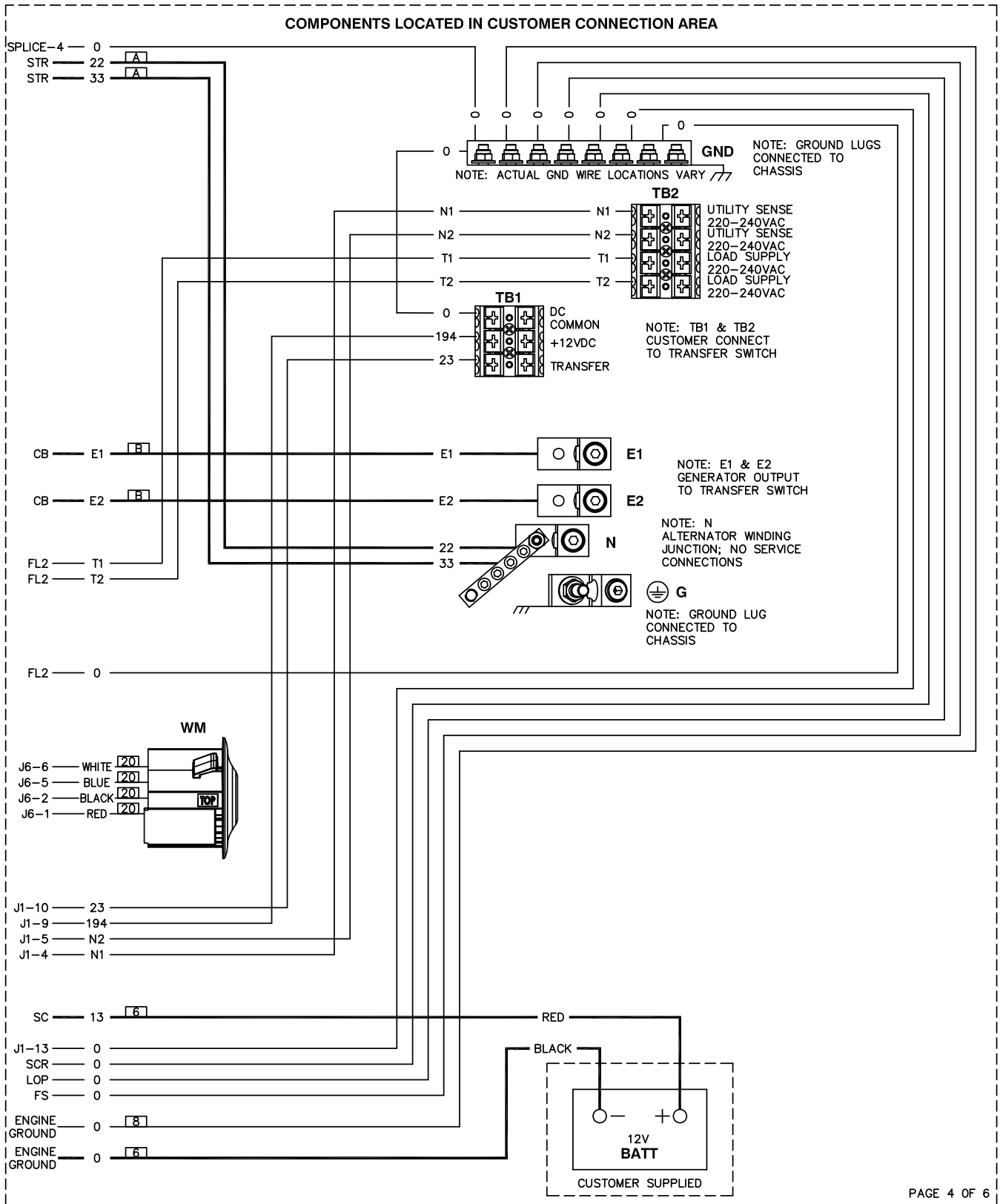

Wiring Diagram (1000007481—5 of 6)

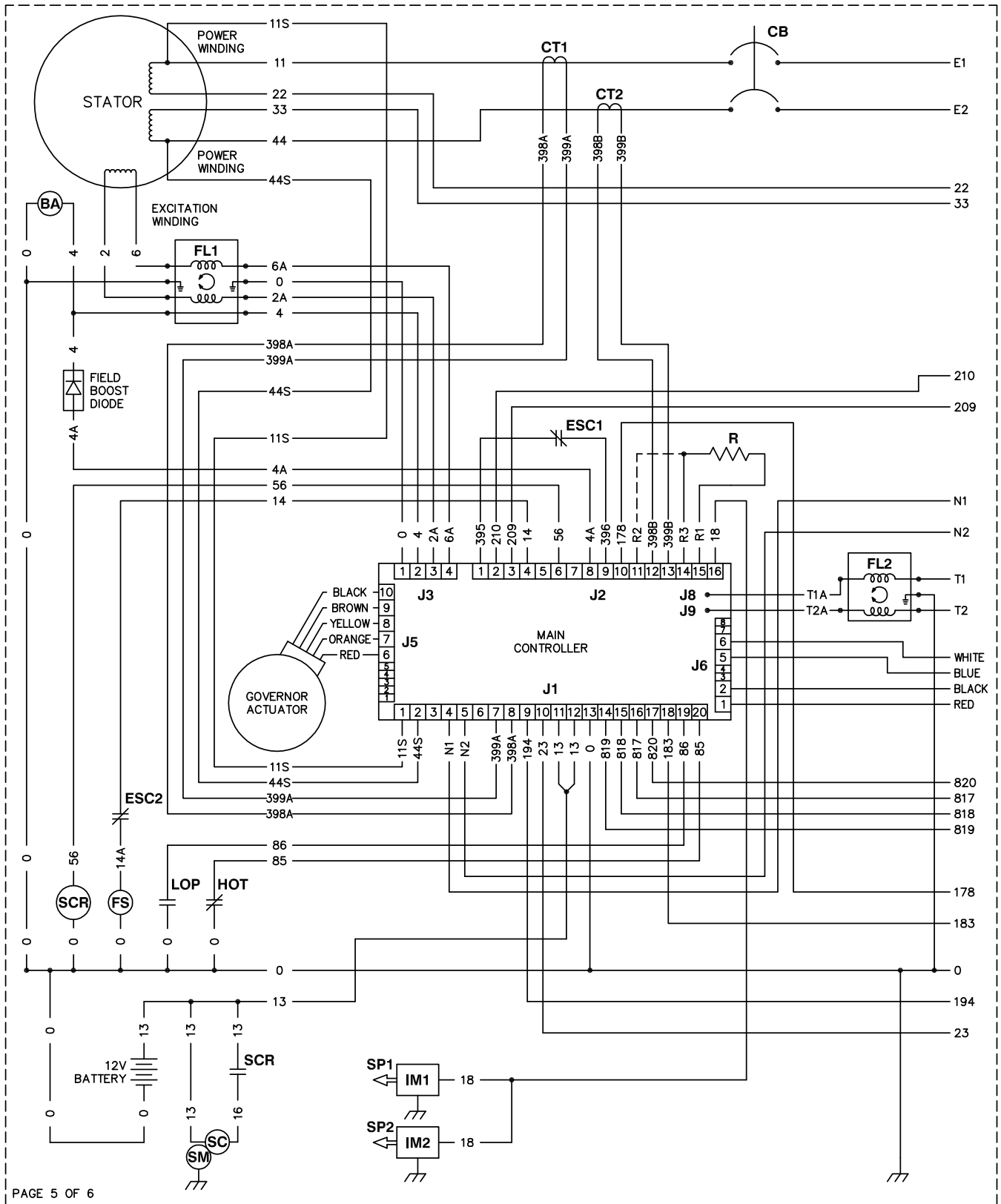

Wiring Diagram (1000007481—6 of 6)

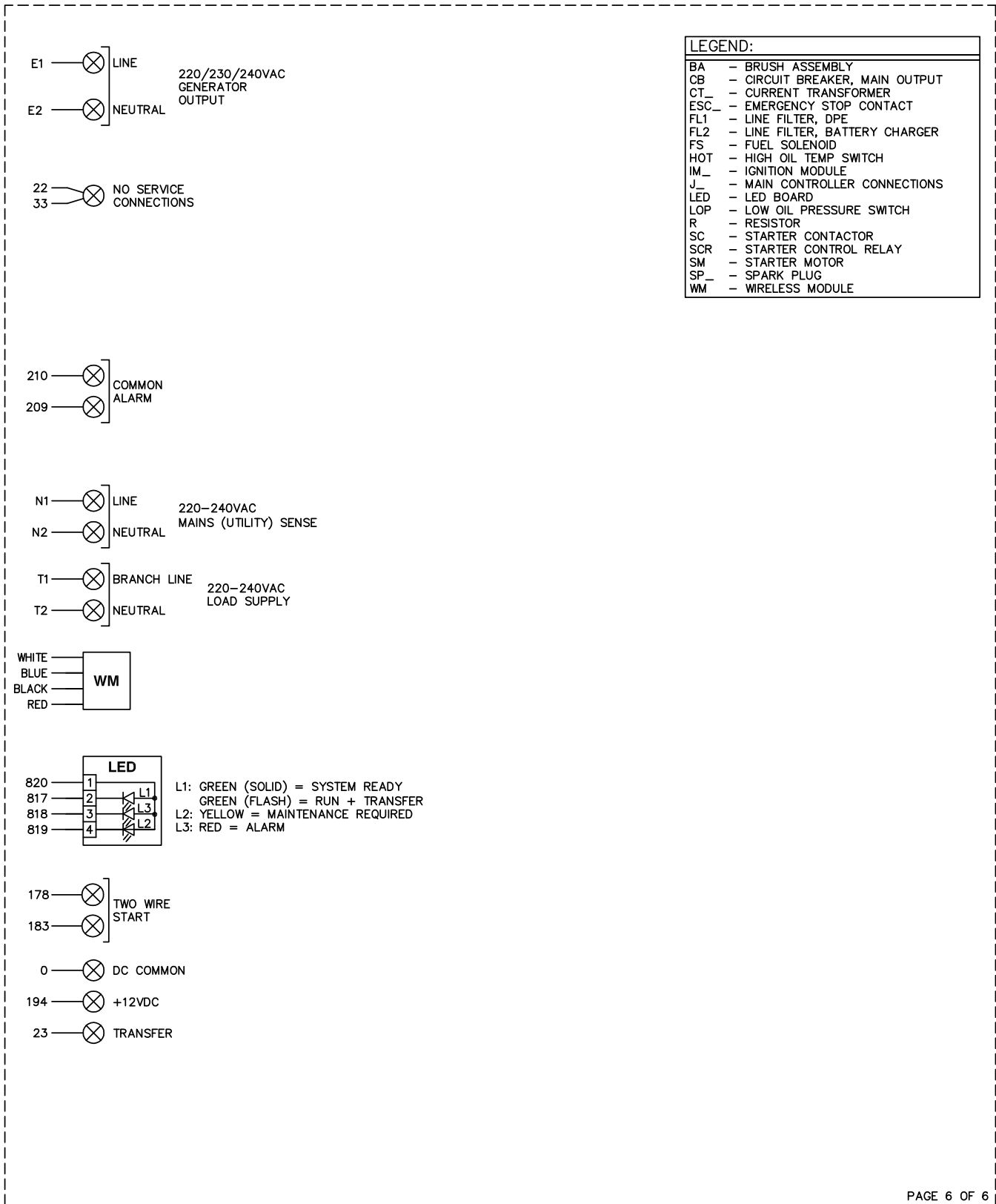

Section 12: Servicing Centers

<p>GPR BRAZIL Rodovia Anhanguera, S/N - SP 330 km 305 + 152 metros Recreio Anhanguera Ribeirão Preto - SP - Brasil CEP 14097-140 Brazil Tel.: +55 16 3505.9100</p>	<p>PRAMAC EUROPE SAS Place Léonard de Vinci 42190 - St. Nizier sous Charlieu France Tel.: +33 (0) 477 692 020 Fax: +33 (0) 477 601 778</p>
<p>PR AFRIQUE Immeuble du Parc N°22 Rue Du Parc, Casablanca Morocco Tel.: +212 5 29 04 08 86</p>	<p>PRAMAC FU LEE FOSHAN No.25 Xinhui Road, Wusha, Daliang, Shunde, Foshan Guangdong 528333 P.R. China Tel.: +86 0757 22804857 Fax: +86 757 22804828</p>
<p>PR AUSTRALIA PTY LTD Suite 202, 59 Kirby Street, Rydalmere, NSW 2116 Australia Tel.: +61 2 9071 8181 Fax.: +61 2 9071 8191</p>	<p>PRAMAC GENERATORS SRL Sos Bucuresti Targoviste Nr 12A, Corp A, Etaj 3 077135 Mogosoia, Ilfov Romania Tel.: +40 314170765 Fax: +40 314170755</p>
<p>PR INDUSTRIAL SRL Località Il Piano 53031 Casole d'Elsa, Siena Italy Tel.: +39 0577 9651 Fax: +39 0577 949076</p>	<p>PRAMAC GMBH Salierstr. 48 70736 Fellbach, Stuttgart Germany Tel.: +49 711 517 4290 Fax: +49 711 517 42999</p>
<p>PR MIDDLE EAST FZE 1706 JAFZA View 18, P.O. Box 262478 Jebel Ali Free Zone - South 1, Dubai United Arab Emirates Tel.: +971 4 8865275 Fax: +971 4 8865276</p>	<p>PRAMAC IBERICA SAU Parque Empresarial Polaris C/Mario Campinoti, 1 Autovía Murcia-San Javier Km 18 30591 Balsicas, Murcia, Spain Tel.: +34 968 334 900 Fax: +34 968 579 321</p>
<p>PRAMAC - GENERAC UK Ltd 5 - 6, Orion Way, Crewe, Cheshire, England, CW1 6NG United Kingdom Tel.: +44 1270 445777 Fax: +44 1270 617036</p>	<p>PRAMAC RUS LTD Neverovskogo street 9, office 316 Moscow Russian Federation Tel.: +7 495 651 68 66 Fax: +7 495 651 68 66</p>
<p>PRAMAC ASIA PTE LTD 10 Bukit Batok Crescent #11-08 The Spire Singapore 658079 Singapore Tel.: +65 6558 7888 Fax: +65 6558 7878</p>	<p>PRAMAC SP. Z O.O ul. Krakowska 141-155 budynek F 50-428 Wrocław Poland Tel.: +48 71 782 26 90 Fax: +48 71 798 10 06</p>
<p>PRAMAC CARIBE SRL Avda. 27 de Febrero, Esq. Caonabo, 664 Los Restauradores 10137 Santo Domingo Dominican Republic Tel.: +1 809 531 0067 Fax: +1 809 531 0273</p>	

Part No. 10000028326 Rev. B 01/18/2019

©2019 Generac Power Systems, Inc.

All rights reserved

Specifications are subject to change without notice.

No reproduction allowed in any form without prior written
consent from Generac Power Systems, Inc.

The logo for PRAMAC, featuring a stylized 'P' icon followed by the word 'PRAMAC' in a bold, sans-serif font.

PR INDUSTRIAL s.r.l.

Località Il Piano snc

53031 Casole d'Elsa, Siena - Italy

Ph: +39 0577 9651

MOUNTING TO CONCRETE PAD

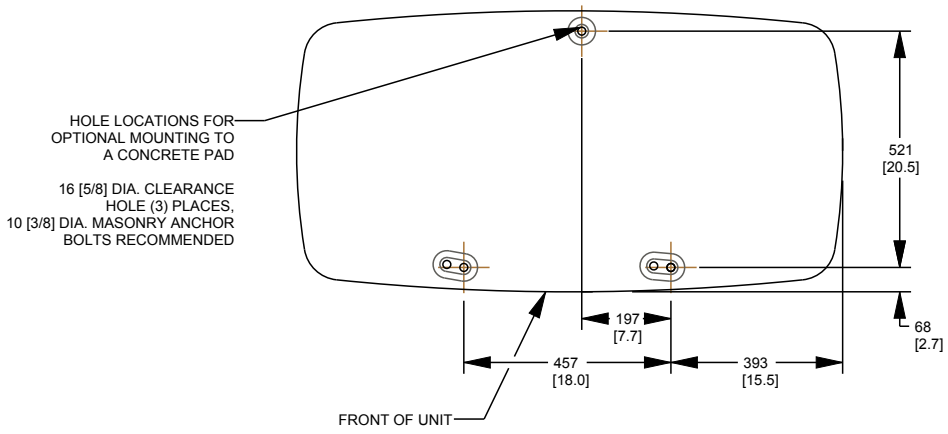

MAIN AC/CONTROL WIRING HOLE FOR 1 1/4" CONDUIT
 MAIN AC/CONTROL WIRING HOLE FOR 3/4" CONDUIT
 WIRELESS MODULE

(REMOVE FACTORY PLUGS AND DISCARD
 -CLOSE ANY UNUSED HOLE WITH A NEMA 3R OR IP44 RATED PLUG (FIELD SUPPLIED))

FUEL INLET : 1/2" NPT (8-13kVA)
 3/4" NPT (20kVA)
 REQUIRED FUEL PRESSURE : NATURAL GAS : 0.87-1.74 kPa [3.5-7" WATER COLUMN]
 LIQUID PROPANE (VAPOR) : 2.49-2.99 kPa [10-12" WATER COLUMN]

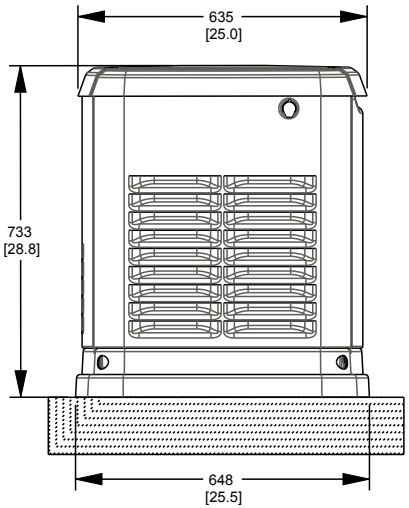
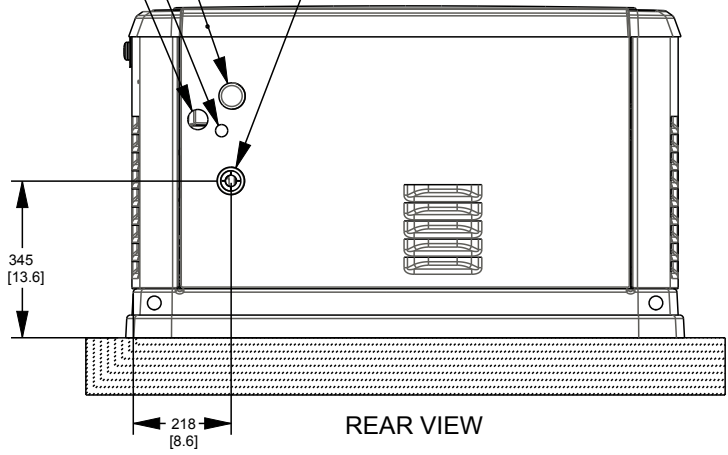

INSTALLATION DRAWING

TITLE
INSTALL HSB 50Hz CE MODELS

SIZE A	CAGE NO N/A	DWG NO 10000010676	REV C
SCALE NTS	WT-KG N/A	SHEET 1 of 2	

ALL DIMENSIONS IN:
MILLIMETERS (INCHES)

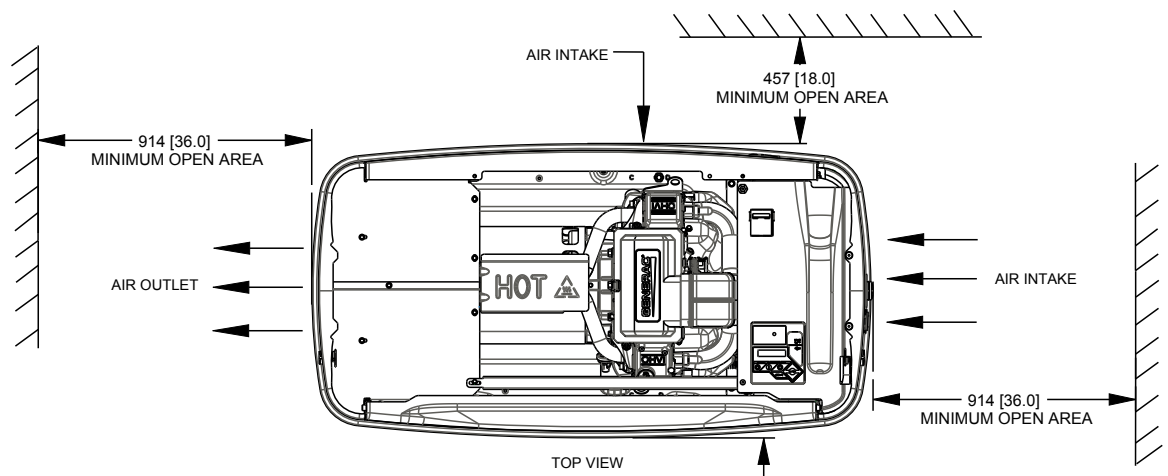

"DO NOT LIFT BY ROOF"

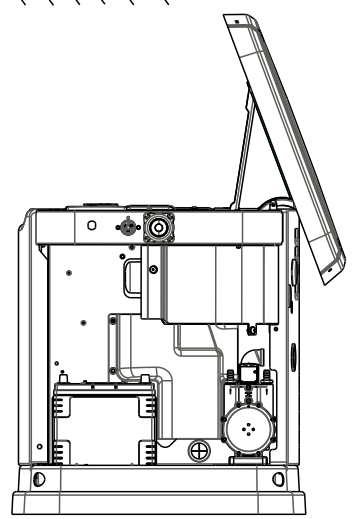
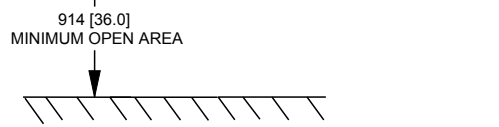
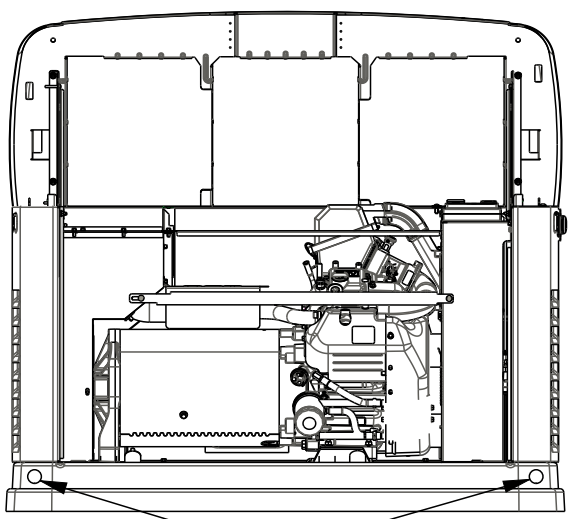

LIFTING HOLES 4 CORNERS: Ø 30 [Ø 1.2]
- MUST BE LIFTED WITH STEEL RODS
- RECOMMENDED LIFTING ROD SIZE: Ø 25 [Ø 1.0]

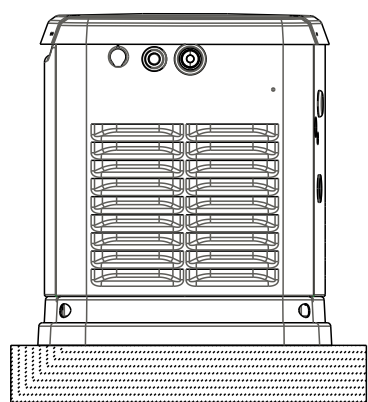
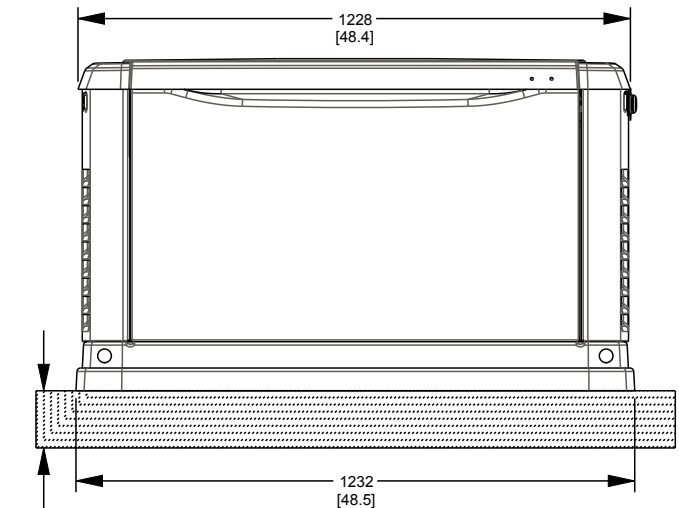

ALL DIMENSIONS IN:
MILLIMETERS [INCHES]

INSTALLATION DRAWING				
TITLE INSTALL HSB 50Hz CE MODELS				
SIZE A	CAGE NO N/A	DWG NO 10000010676	REV C	
SCALE NTS	WT-KG N/A	SHEET 2 of 2		

COMPONENTS LOCATED ON ENGINE

LEGEND:

- BA - BRUSH ASSEMBLY
- BATT - BATTERY
- BCH - BATTERY CHARGER
- CB - CIRCUIT BREAKER, MAIN OUTPUT
- CT_ - CURRENT TRANSFORMER
- ESC_ - EMERGENCY STOP CONTACT
- FL1 - LINE FILTER, DPE
- FL2 - LINE FILTER, BATTERY CHARGER
- FS - FUEL SOLENOID
- GND - GROUND
- HOT - HIGH OIL TEMP SWITCH
- IM_ - IGNITION MODULE
- J_ - MAIN CONTROLLER CONNECTIONS
- J3F - LINE FILTER BEFORE J3
- LED - LED BOARD
- LOP - LOW OIL PRESSURE SWITCH
- MAG - MAGNETO
- N - ALTERNATOR WINDING JUNCTION
- R - RESISTOR
- SC - STARTER CONTACTOR
- SCR - STARTER CONTROL RELAY
- SM - STARTER MOTOR
- SP_ - SPARK PLUG
- STR - STATOR
- TB_ - TERMINAL BLOCK
- WM - WIRELESS MODULE

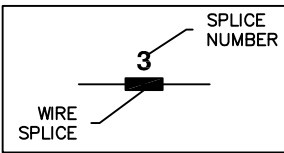
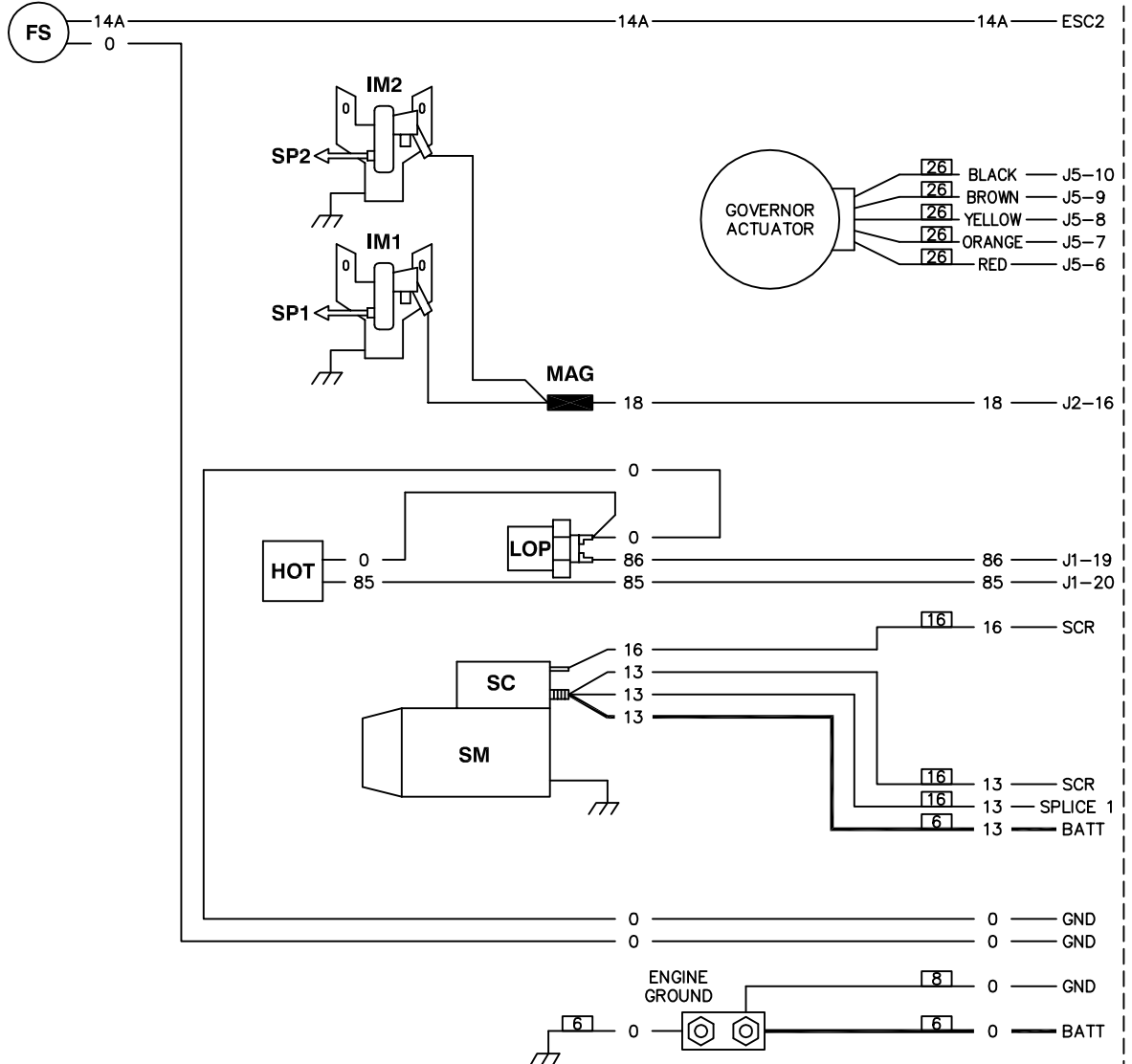
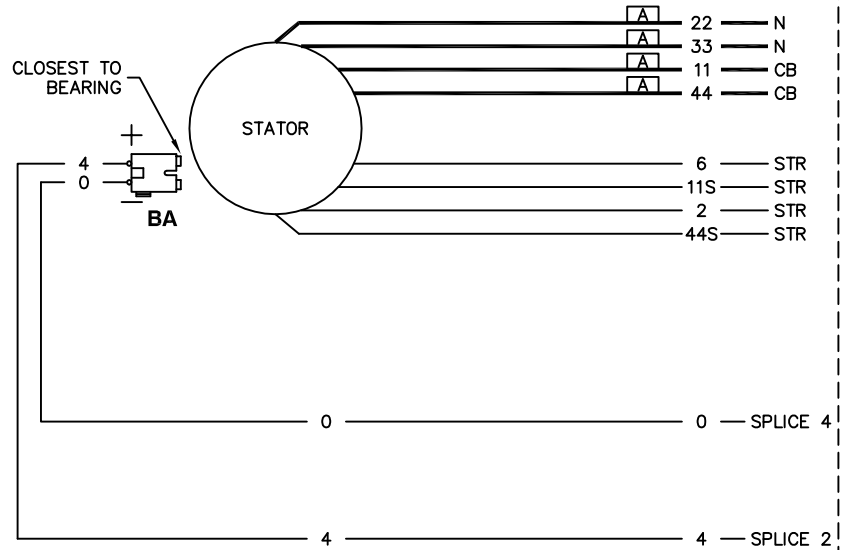

NOTE: ALL WIRES 18 AWG 300V UL LISTED UNLESS SHOWN OTHERWISE.

AWG SIZE: [12]

OR

AWG CHART LETTER REF.: [XX]

GENERATOR SIZE	AWG "A"	AWG "B"
8-10KVA	8	8
13KVA	8	4

COMPONENTS LOCATED IN CONTROL PANEL

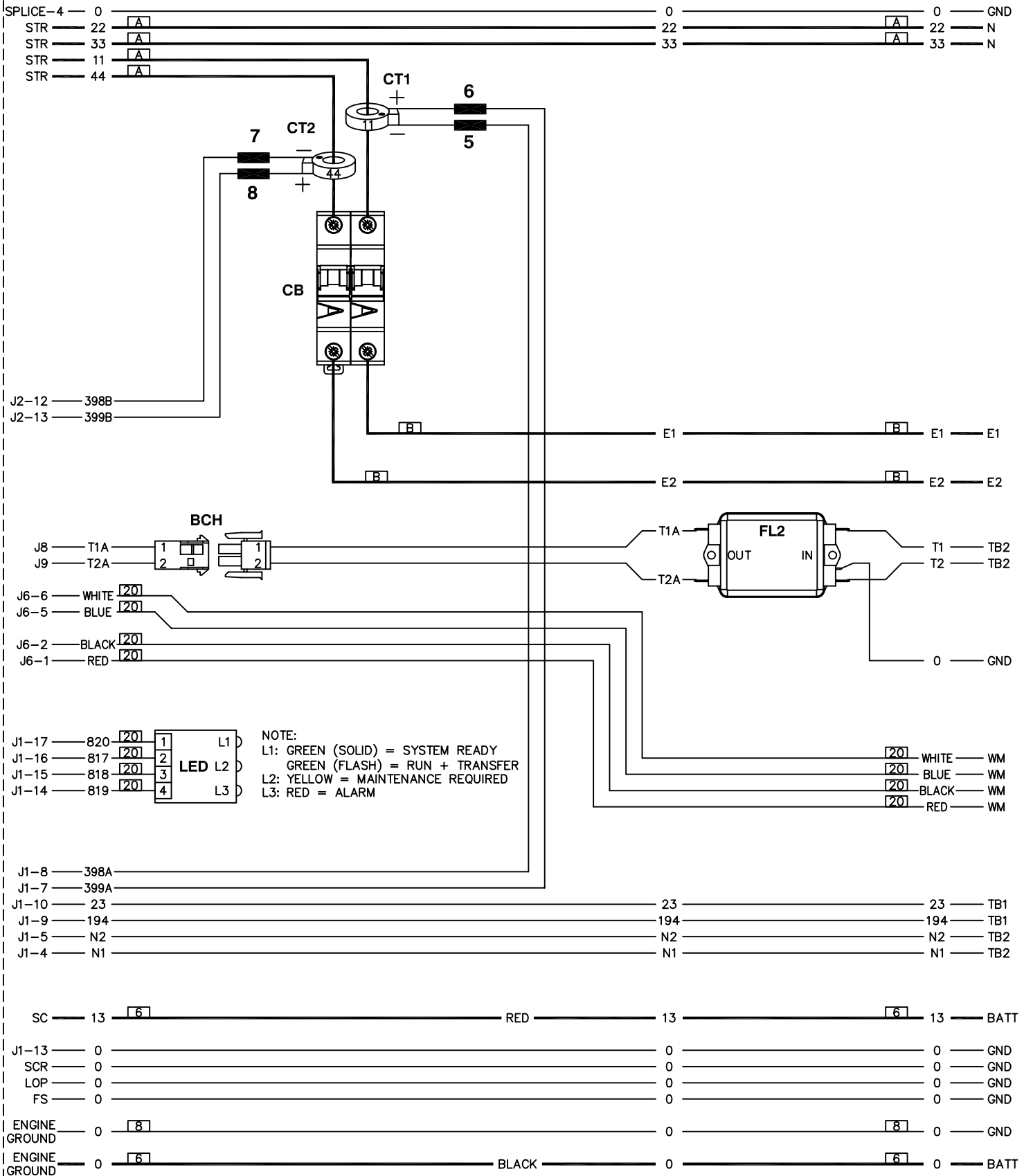

COMPONENTS LOCATED IN CUSTOMER CONNECTION AREA

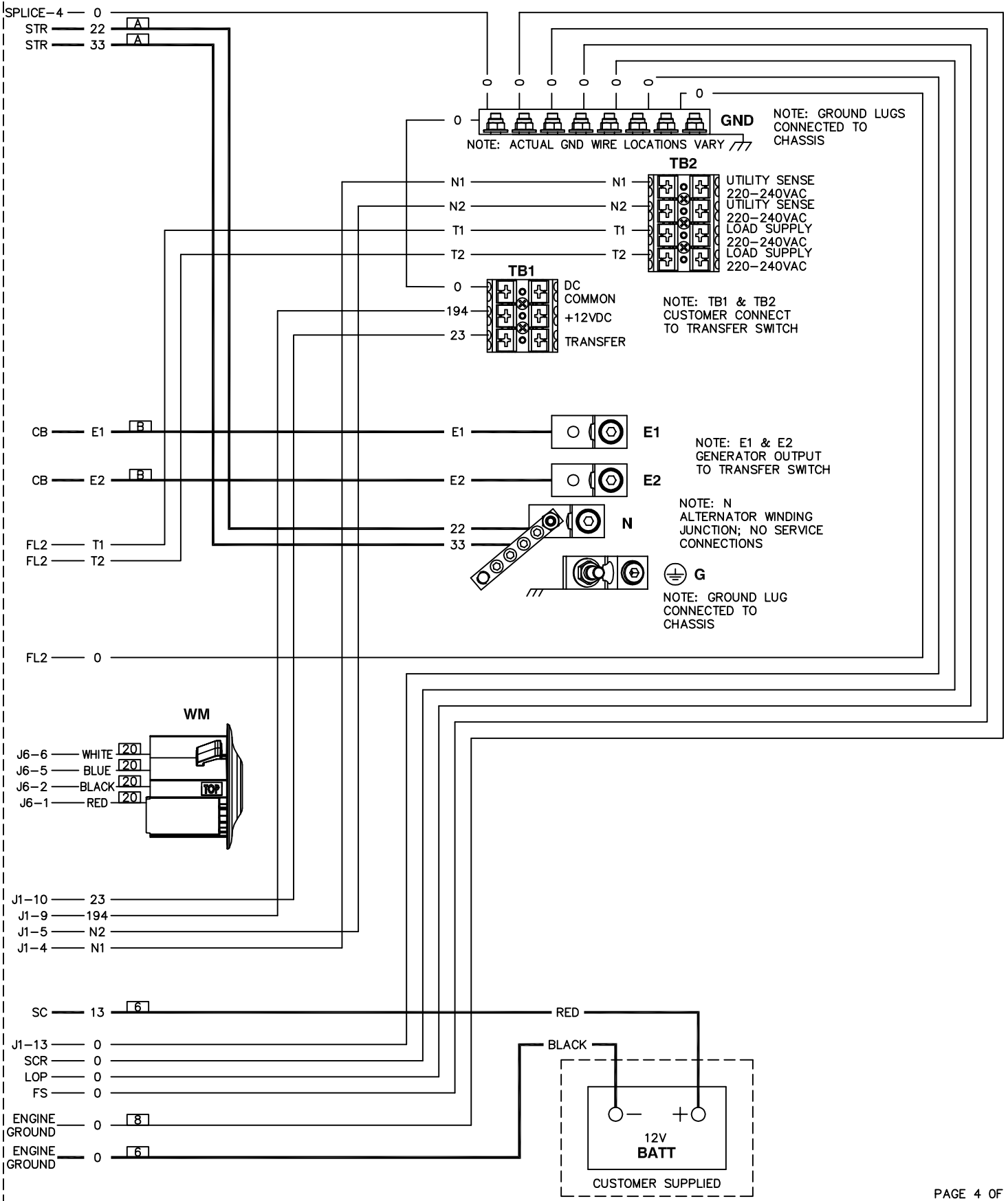

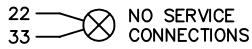
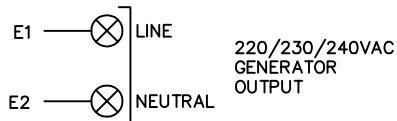

LEGEND:	
BA	- BRUSH ASSEMBLY
CB	- CIRCUIT BREAKER, MAIN OUTPUT
CT_	- CURRENT TRANSFORMER
ESC_	- EMERGENCY STOP CONTACT
FL1	- LINE FILTER, DPE
FL2	- LINE FILTER, BATTERY CHARGER
FS	- FUEL SOLENOID
HOT	- HIGH OIL TEMP SWITCH
IM_	- IGNITION MODULE
J_	- MAIN CONTROLLER CONNECTIONS
LED	- LED BOARD
LOP	- LOW OIL PRESSURE SWITCH
R	- RESISTOR
SC	- STARTER CONTACTOR
SCR	- STARTER CONTROL RELAY
SM	- STARTER MOTOR
SP_	- SPARK PLUG
WM	- WIRELESS MODULE

