

Uninterruptible power supply UPS

COVER NGS

10-40 kVA

User manual

The content of this document is protected by the copyright of the publisher and can not be reproduced without prior permission. Subject to modification of design and specifications without prior notice.

©Copyright 2016
COMEX S.A.
All rights reserved.

Tabelle of contents

1.	Precautions	1
2.	Installation procedure.....	3
2.1.	Introduction.....	3
2.2.	Preliminary review	3
2.3.	Location	4
2.3.1.	UPS room	4
2.3.2.	Battery room.....	4
2.3.3.	Storage	4
2.4.	Unpacking, checking and setting up	4
2.4.1.	Unpacking	4
2.4.2.	Design and dimensions of the UPS	6
2.4.3.	Service space.....	8
2.5.	Security systems.....	9
2.5.1.	UPS input power	9
2.5.2.	Battery circuit protection.....	9
2.6.	Power supply cables.....	11
2.6.1.	Maximum power supply currents.....	12
2.6.2.	Connecting wires.....	13
2.7.	Internal battery connections.....	14
2.8.	Communication cables.....	15
2.8.1.	Dry Contact - sensor for detecting battery temperature and environment	16
2.8.2.	REPO switch port	16
2.8.3.	External bypass interface.....	17
2.8.4.	Interface to BCB battery switch	18
2.8.5.	Output signal - Low battery	18
2.8.6.	Output signal - event warning	19
2.8.7.	Output signal - no power supply.....	19
2.8.8.	Port USB, RS-232 and RS-485.....	20
2.8.9.	SNMP slot and parallel card slot.....	20
3.	UPS operating modes.....	21
3.1.	Introduction.....	21
3.2.	Principle of operation.....	21
3.2.1.	Bypass module	22
3.3.	Modes of operation of the power supply	22
1.	Normal mode.....	22
2.	Battery mode	22
3.	Autorestart	23
4.	Bypass mode.....	23
5.	Service bypass.....	23
6.	Economical (ECO).....	23
7.	Frequency converter	23

4.	Power Supply User's Guide	24
4.1.	Power Switches	24
4.2.	Procedures to start the power supply	27
4.2.1.	Start up the UPS from full shutdown.....	27
4.2.2.	Starting the UPS from the battery (for UPS with "Cold start").....	28
4.3.	Procedures for switching the power supply between modes	28
4.3.1.	Switching from normal to battery mode	28
4.3.2.	Switching from Normal to Bypass mode	28
4.3.3.	Switching from Bypass mode to normal operation.....	28
4.3.4.	Switching from Normal to Service bypass mode.....	29
4.3.5.	Switching from Service Bypass mode to normal operation	29
4.4.	Complete power off procedure	29
4.5.	Emergency shutdown with EPO	30
5.	Operation of the LCD panel	31
5.1.	Introduction.....	31
5.1.1.	LED indicators	32
5.1.2.	Audible alarm.....	32
5.1.3.	Function keys	32
5.2.	LCD screen.....	33
5.2.1.	System information.....	34
5.3.	Detailed list of information available on the LCD panel	35
5.4.	List of events and alarm	37

1. Precautions

This user manual contains the necessary information regarding the installation and use of COVER series NGS power supplies.

Before beginning installation and use, you are asked to read this manual carefully. The UPS must be installed and configured by an authorized service center of the manufacturer or distributor. In the case of installation by people without the required experience, there is a risk of users being exposed to health or life. Persons not authorized to install may damage the power supply, which in this case is not subject to warranty conditions.



COMPLETE STANDARDS

The device complies with the directive CE 73/23 and 93/68 (low voltage safety) and also 89/336 (EMC) and the following standards:

*IEC62040-1-1

*IEC/EN62040-2 EMC CLASS C3

*IEC62040-3



NOTE - High leakage current

Connecting the protective conductor (PE) is essential and must be done before connecting the remaining working cables (power supply, receiving, battery).

Grounding should be carried out in accordance with prevailing standards and practical on-site knowledge.

The leakage current exceeds 3.5 mA and is less than 1000 mA.

When selecting RCCB or RCD devices for immediate operation, the transient and fixed leakage currents that may occur during commissioning must be considered.

Automatic residual current circuit breakers (RCCBs) that are sensitive to DC unidirectional (Class A) pulses and are insensitive to transient current pulses shall be selected.

Also note that the RCCB or RCD device will conduct the leakage current of the receiver.



Operation

There is dangerous voltage in the UPS housing. The risk of contact with such voltage is minimized as the live parts are behind the enclosure. Additional internal protection guards ensure that the device is protected in accordance with IP20 protection class.

Normal operation of the device, taking into account recommended operating procedures, does not pose any risk to personnel.

All maintenance and service procedures require access to the inside of the machine and should only be carried out by trained personnel.



High battery voltage > 400 Vdc

All maintenance and installation work may be performed by a properly trained service technician.

After connecting the battery the voltage at their terminals exceeds 400 Vdc and is potentially fatal.

Battery manufacturers give detailed precautions that must be followed when working on or near large battery packs. Such measures must always be strictly observed. Special attention should be paid to recommendations regarding local environmental conditions and the provision of protective clothing, first-aid and fire-fighting equipment.

2. Installation procedure

This chapter is dedicated to the installation method, how to mount and wiring the UPS.

2.1. Introduction

This chapter describes the basic requirements for the positioning and wiring of the power supply. This description is a step-by-step installation guide, which provides a number of guidelines for how to guide your service during assembly.



Warning - Installation may only be carried out by an authorized service center

1. Do not connect electrical equipment to the power supply before confirming that the power supply is properly connected and configured.
2. The UPS should be installed by qualified technicians in accordance with the guidelines in this chapter.

Do not perform any electrical work that interferes with the electrical installation before and after the UPS while the UPS is operating. Damage arising from this title (eg phase sequence replacement) is not covered by the warranty.



Warning: dangerous batteries

Special precautions must be observed when working with batteries connected to the power supply. After connecting the battery, the voltage at the terminals exceeds 400 Vdc and is potentially fatal.

It is recommended to use protective eyewear to protect your eyes from accidental electric arc. In addition, it is recommended that:

- Remove rings, watches and all metal objects.

- Only use tools with insulated handles.

- If the battery leaks or the battery is otherwise damaged, replace it. Damaged batteries should be stored in a container resistant to sulfuric acid and disposed of in accordance with local regulations.

- If the electrolyte comes in contact with the skin, the contaminated area should be washed immediately with water.

2.2. Preliminary review

Please perform the following checks before installation:

- Verify that the supplied equipment, ie UPS and batteries, is not damaged by shipping. Any damage should be reported immediately to the supplier.

- Verify the compliance of the supplied equipment with the installation requirements. The power of the power supply is described on the label each time.

2.3. Location

2.3.1. UPS room

The UPS is designed for indoor installation. The device should be in a clean, ventilated environment in order to maintain the ambient temperature within the required specifications. The UPS provides forced convection cooling through internal fans. Cold air enters the unit through the ventilation openings located in the front of the enclosure and is blown out by the grills in the rear of the enclosure. Do not block the ventilation openings.

Depending on the conditions of the room, the ventilation openings of the power supply should be regularly cleaned, eg with a vacuum cleaner. Ventilation will ensure efficient cooling and longer service life.

Note: The UPS should be installed on a stable and non-flammable surface.

2.3.2. Battery room

The battery temperature should be stable as it is the main parameter that affects battery life and capacity. The optimal operating temperature of the battery is 15-25 ° C. It is recommended to maintain a nominal temperature of 20 ° C.

Working at higher temperatures shortens the battery life and reduces the battery capacity in the lower battery. Each increase in battery operating temperature by another 8 ° C, reduces the service life by 50%.

Keep batteries away from heat sources and hot air outlets.

When installing the battery outside the UPS, use the battery circuit as close as possible to the battery. The connecting cables for the batteries and UPS should be as short as possible.

2.3.3. Storage

If the device is not installed and needs to be stored, protect it from excessive humidity and high temperatures. Keep batteries in a dry and cool place. The most suitable storage temperature for batteries is 20-25 ° C. If the unit is not installed immediately, store it indoors to protect it from excessive humidity and heat sources.

2.4. Unpacking, checking and setting up

Before unpacking, carefully inspect the package provided or damage during transportation. After removing from the package, check that the equipment does not show signs of damage. If there are any damages, please notify the supplier immediately.

2.4.1. Unpacking

The power supply is delivered in a cardboard package on a wooden pallet. For unpacking, remove the carton and foam inside the package. Below is shown the device after dismantling the package.

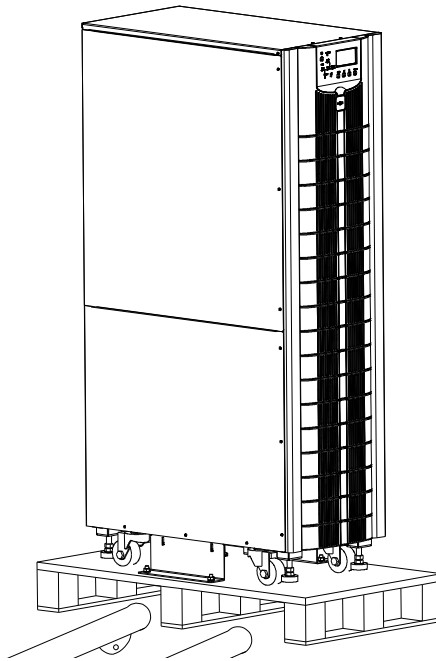
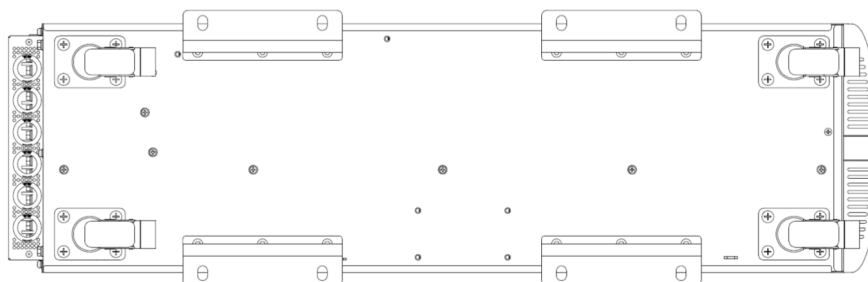

Figure 2-1 View of the power supply after dismantling the packaging

Tip: Remove the screws connecting the UPS power casing to the wooden pallet, and then place the UPS at the installation point. Disassembly should be carried out with care not to scratch the case.

The figure below shows the view of the power supply base, the location of the drive wheels, and the UPS stabilizing components when it is positioned at the destination.

Verify that the supplied equipment is properly labeled on the back of the UPS door. The label contains basic information about model, power, etc.



Note: Remaining materials (timber, plastic, etc.) must be disposed of in accordance with applicable local environmental regulations.

In order to prolong the life of the device, a suitable installation site should be provided to ensure that:

- Easy to connect to the electrical system
- Sufficient space to handle
- Ventilation or air conditioning to ensure adequate cooling of the power supply
- Protection against gases and vapors that may cause corrosion
- Protection against excessive humidity and heat sources

Protection against dust, dust and other contaminants

Proper fire protection

The working temperature should be between 20 and 25°C. At such temperatures, the batteries show optimum performance.

2.4.2. Design and dimensions of the UPS

The appearance and dimensions [mm] of the UPS are shown in the figures below:

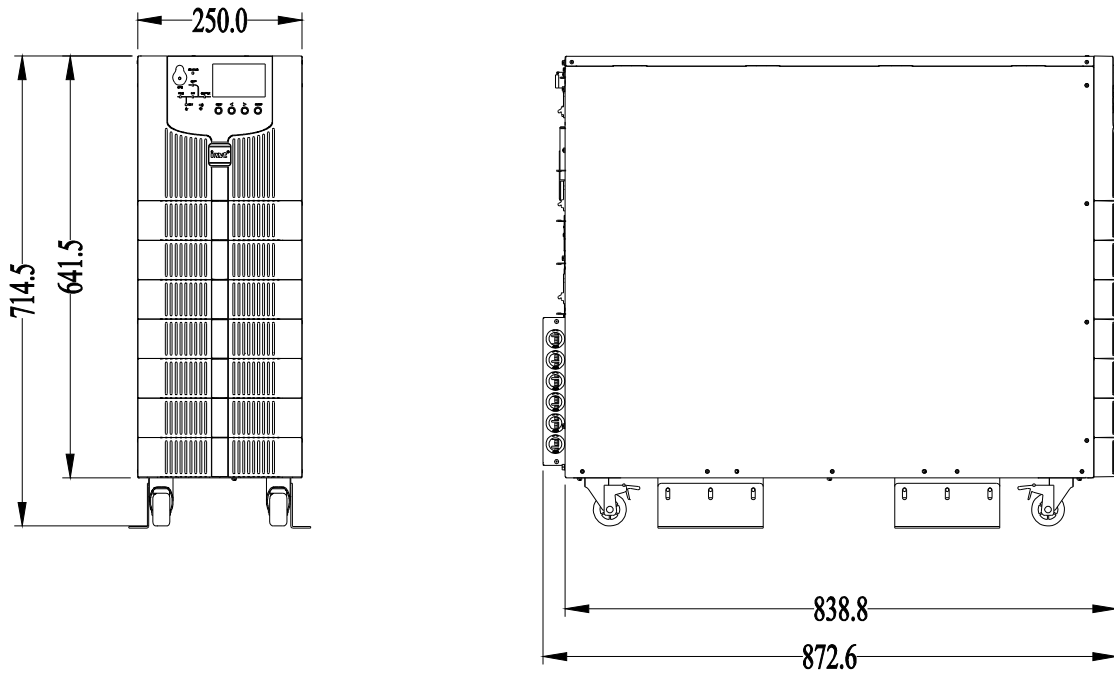

Figure 2-2 Front view / side of UPS NGS 10-15

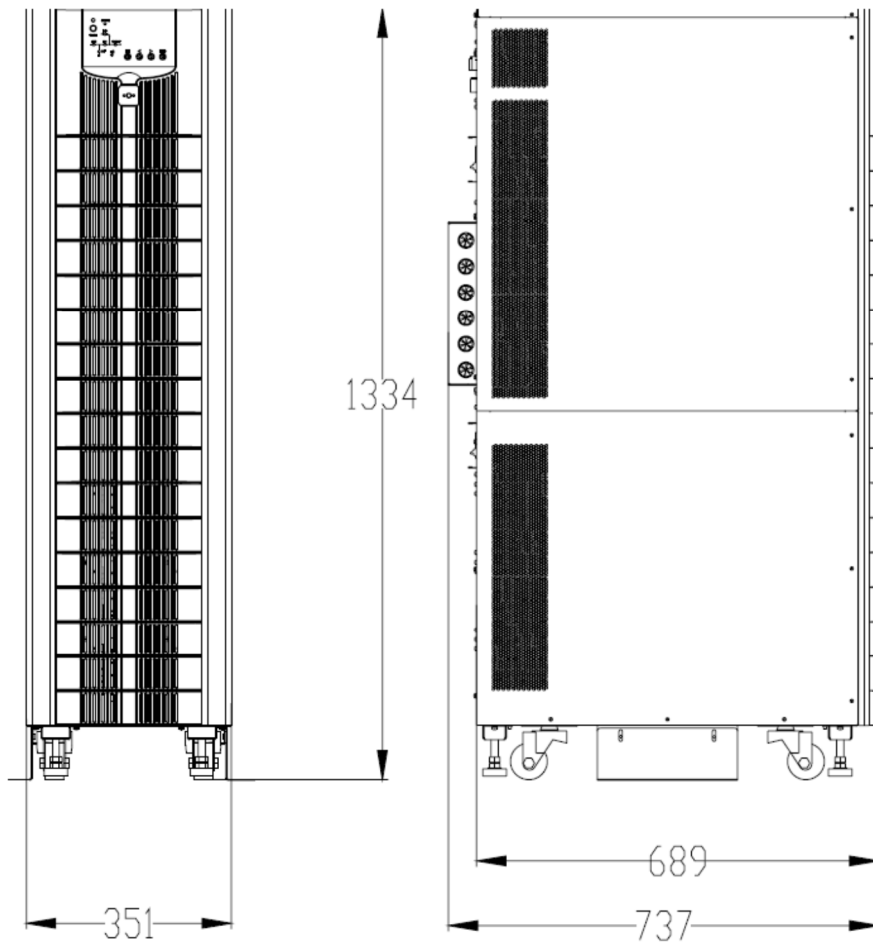

Figure 2-3 Front view of the UPS NGS 20-30.

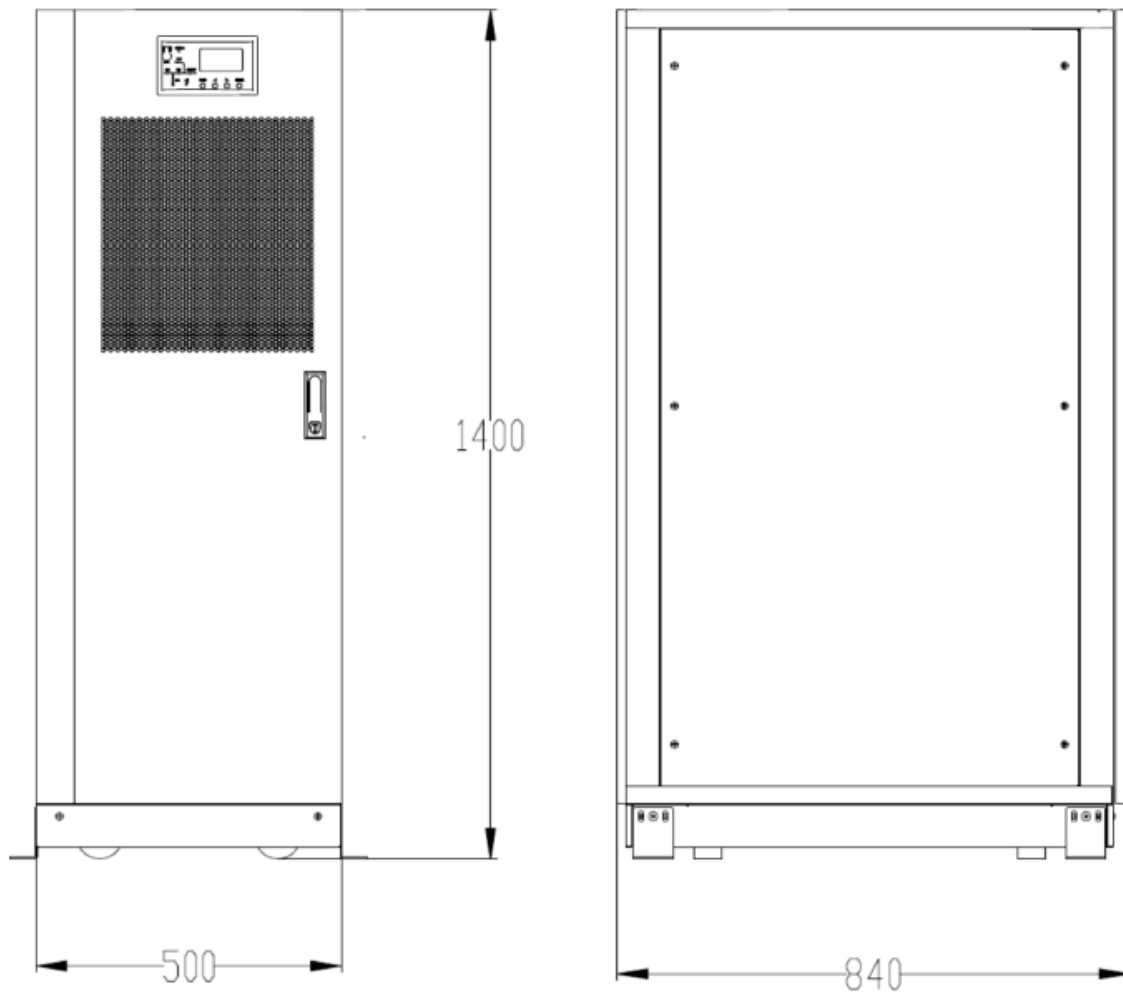

Figure 2-4 Front view of the UPS NGS 40.

2.4.3. Service space

On the side walls of the power supply unit there are no ventilation openings, therefore no space is required on the side for ventilation purposes. For access to the device on each side, it is recommended to keep min. 50 cm service area.

It is necessary to provide adequate space from the front of the power supply for easy operation and the ability to draw cold air from the environment. Recommended 80 cm front space.

Due to the required access to the back of the power supply and free airflow and circulation, the recommended back space of the power supply is 50 cm.

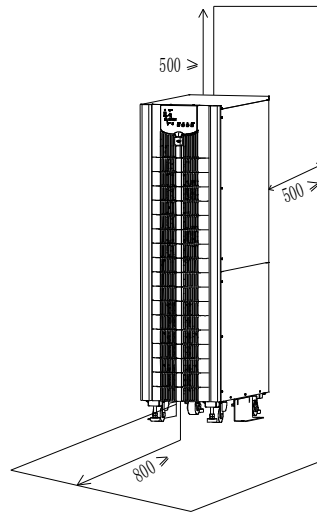

2.5. Security systems

For safety reasons, it is necessary to install appropriate protections in the form of surge suppressors or other protective devices in the UPS distribution board. This chapter provides general practical information for installation by qualified electricians. In addition, staff with the appropriate knowledge and authority should be aware of the standards and standards applicable to the local market for type and cross-section of wires, their arrangement and their load capacity. It is recommended to use flexible hoses type LgY or OpD.

2.5.1. UPS input power

The UPS should be powered from an electrical switchgear equipped with a suitable security apparatus selected for maximum system power and flexible hoses with appropriate current carrying capacity selected for the protection used.

If you need to install RCDs on the UPS power supply, keep in mind that these units should:

- Be sensitive to unidirectional DC current pulses (Class A)

- Not be sensitive to transient current impulses

- Adjustable sensitivity range 0.3 - 1A.

The RCD must be sensitive to unidirectional DC current pulses and insensitive to transient current pulses as shown below:

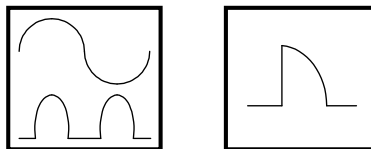

Figure 2-5 RCD switch designation

2.5.2. Battery circuit protection

The battery required for proper operation of the power supply consists of a standard of 40 12 V batteries connected in series. A 3 watt lead with center neutral is required, taken from a central connection between battery 20 and 21. The battery circuit must be protected by a suitable fuse that is rated for the power of the UPS.

A detailed drawing of the battery installation is shown below:

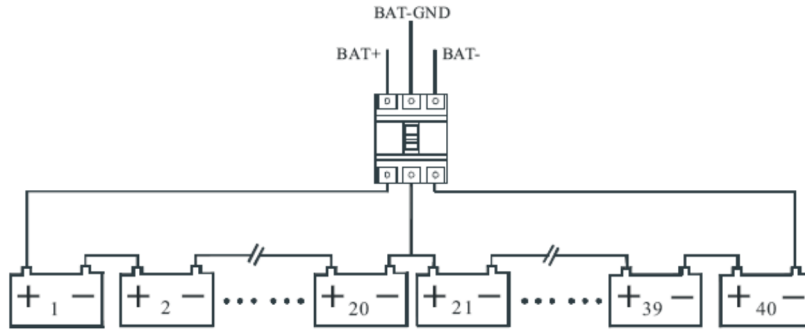

Figure 2-6 Diagram of serial connection of 40pcs batteries with central neutral point

2.6. Power supply cables

The main factors that affect the selection of wires are the supply voltage, current, and room temperature and cable installation conditions.

The power supply cables of the system must be selected in accordance with the applicable regulations at the site and comply with the following description:

Input power cords must be matched to the maximum input current and maximum charging current shown in the table below, including the power rating of the power supply and AC input voltage.

Output and bypass cables must be matched to the rated output currents given in the table, taking into account the power rating of the power supply and the AC output voltage.

Battery cables must be matched to the battery discharging current at the end of the discharge voltage given in the table, taking into account the power rating of the power supply.

The terminal block for connecting the power / receiving cables is located on the back of the power supply.

Bolts with eyelet for M6 bolt, screw tightening torque of 4.9Nm.

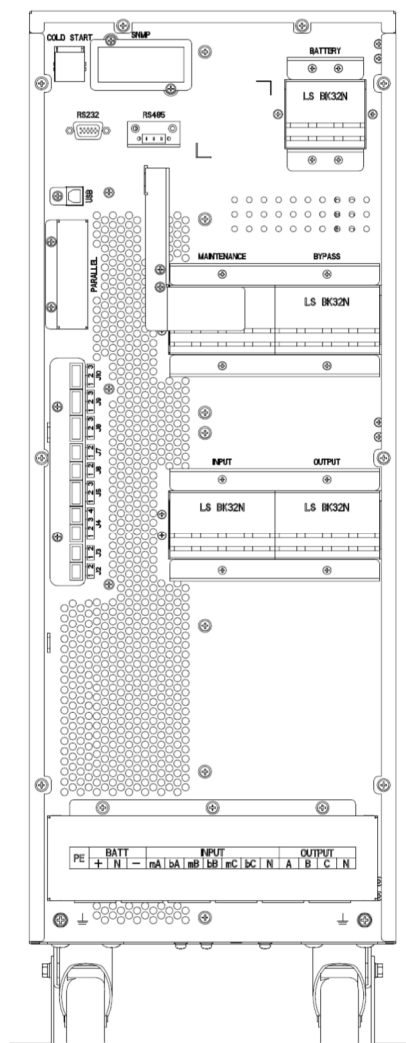

Figure 2-7 View of the rear of the power supply and the cable approach NGS 10-30K

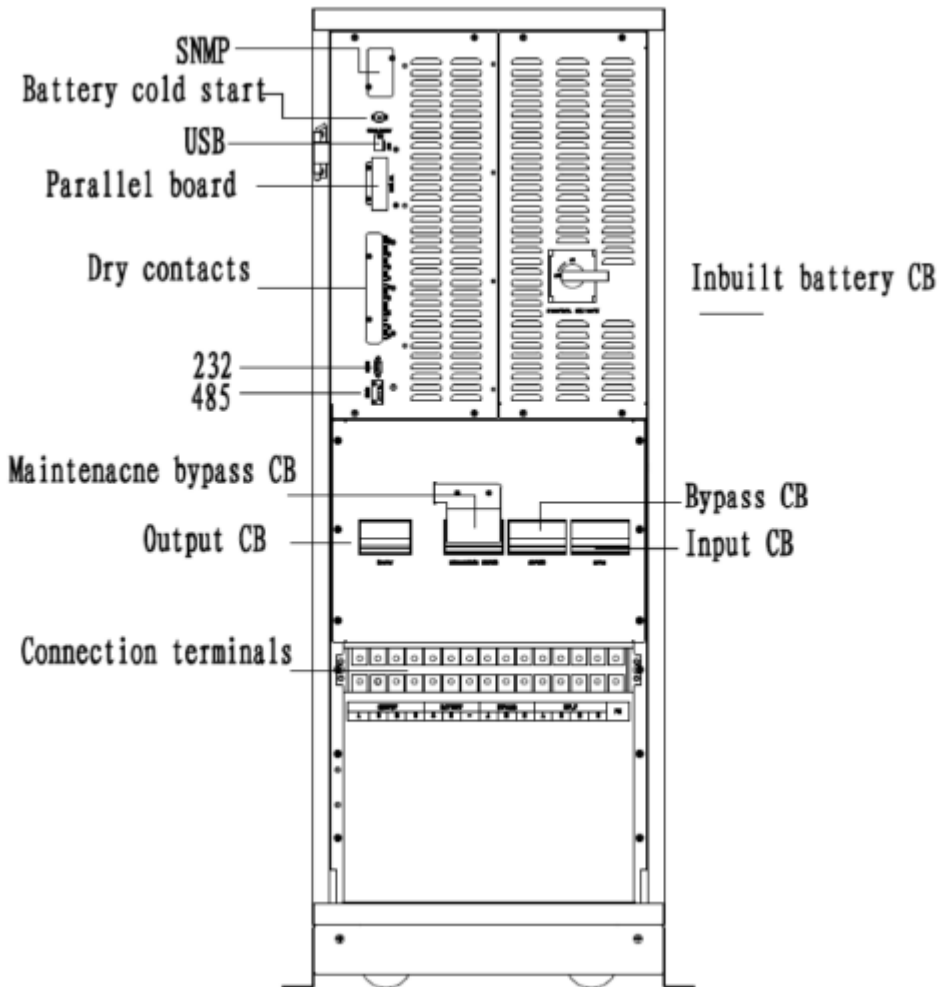

Figure 2-8 View of the rear of the power supply and the cable approach NGS 40K

Attention
<p>BEFORE PERFORMING THE POWER SUPPLY CIRCUIT MUST HAPPEN TO THE POSITION AND OPERATION OF THE EXTERNAL SWITCH TO CONNECT THE INPUT / OUTPUT SUPPLY OF THE POWER SUPPLY WITH THE NETWORK DISTRIBUTION PANEL. CHECK THAT THE ABOVE POWER SOURCES ARE ELECTRICALLY DISCONNECTED AND TO MAKE NECESSARY WARNING CONTROLS TO BE UNINDED THAT THEY ARE INCIDENTALLY ACTUALLY ACTUALLY ONCE THAT THE UPS SHOULD NOT SHOW ON THE CABLE AT THE UPS.</p>

2.6.1. Maximum power supply currents

The following table shows the currents for the maximum system power, depending on the power system. These currents are used to select the appropriate protection in the power, battery and receiver paths and the corresponding cable cross-sections. Currents given at a 230 / 400Vac installation.

Table 2-1 Table of power supply currents

System		NGS 10	NGS 15	NGS 20	NGS 30	NGS 40
Power		10 kVA	15 kVA	20 kVA	30 kVA	40 kVA
Dimensions [mm] (W x D x H)		250 x 872,6 x 714,5		350 x 737 x 1335		500 x 840 x 1400
Supply	Nominal current [A]	18	28	35	55	70
Output	Nominal current [A]	15	23	30	45	60
Battery	Nominal current [A]	20	30	40	60	80

 **Warning**

The power supply needs to be connected to the PE protective conductor. Incorrect connection of the protective conductor may cause malfunction of EMI filters and result in electric shock or fire.

2.6.2. Connecting wires

 **Warning**

The operations described in this section should be performed by a suitably trained service team. The contractor is responsible for preparing the power supply and the power supply to the power supply.

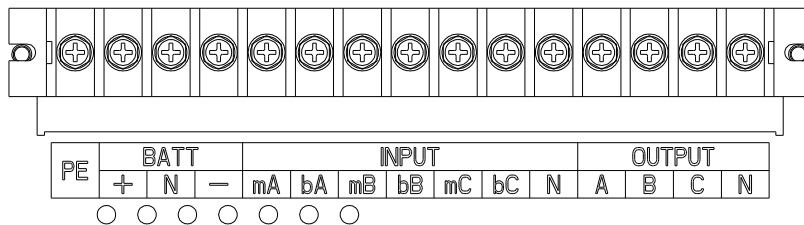

Figure 2-4 View of the terminal block for connection of NGS 10-15 cables

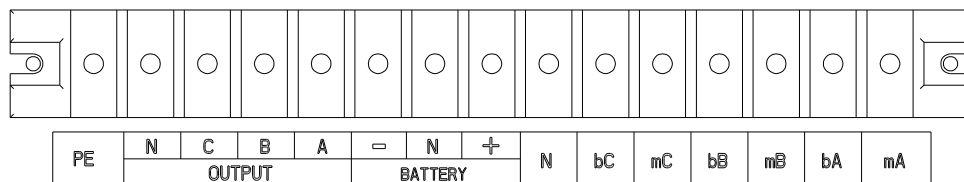

Figure 2-5 View of the terminal block for connection of NGS 20-30 cables

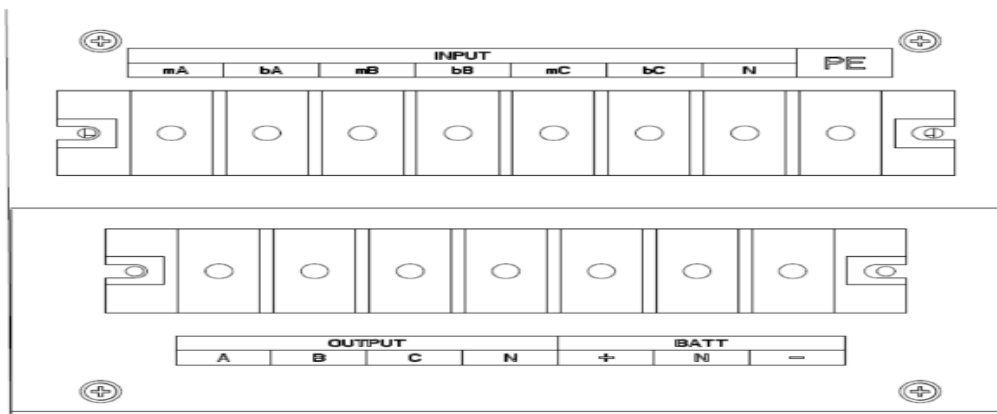

Figure 2-9 View of the terminal block for connection of NGS 40 cables

After properly aligning and securing the power supply from moving, connect the wires with the following rules:

1. Check that the power supply is completely disconnected from the external power source and that the Service bypass switch on the power supply is open. Ensure that these power sources are electrically isolated and arrange the necessary warning signs to prevent accidental activation.
2. Open the rear door of the power supply and remove the cover to gain access to the power supply. The terminal block for connecting cables is located on the front of the power supply.
3. Connect the earth ground wire. The connection must comply with local regulations and standards.
4. Connect the power supply cables to the input (Main Input mA-mB-mC-N), output leads are output A-B-C-N. Check the correct sequence (rotation) of the phases. When connecting two paths with separate rectifier and Bypass path power supply, the bridges connecting the rectifier and bypass inputs (mA-bA; mB-bB; mC-bC) must be dismantled.
5. Connect the power cords between the UPS and the battery disconnect switch. Check correct polarity.



Warning - Dangerous voltage on battery terminals

Make sure that the polarity of the battery is correctly connected. Battery positive terminal for positive terminal (BAT +) on UPS, negative battery terminal for negative terminal (BAT-) on UPS, neutral terminal for neutral terminal (N) on UPS.

6. Replace the protective cover and the rear cover of the power supply.

2.7. Internal battery connections

The NGS 10-15-20-30 series power supplies allow you to install batteries inside.

Standard UPS NGS 10-15 is designed to mount 40 batteries 7 / 9Ah / 12V, while NGS 20-30 to install 40 batteries 12Ah / 12V or 2x32x9Ah.

The following figure shows the assembly and location of the battery inside the device.

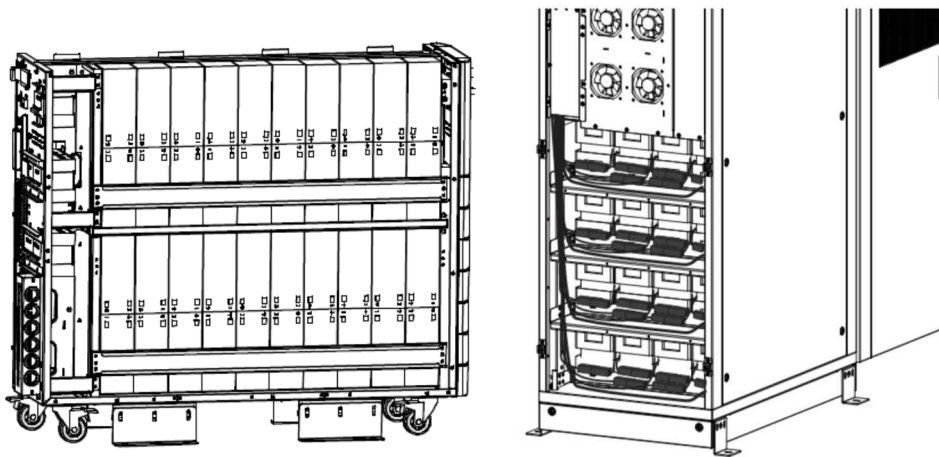

Figure 2-10 View of battery location and connection depends on UPS model

2.8. Communication cables

As shown in the figure below, the power supply interface is located at the back of the power supply, and consists of a contact interface (Dry Contact J2-J10), a USB communication interface, RS-232, RS-485, parallel card slot and SNMP card slot. There is also a button called. A "cold start", which allows the battery to run from a battery even when the power supply is off.

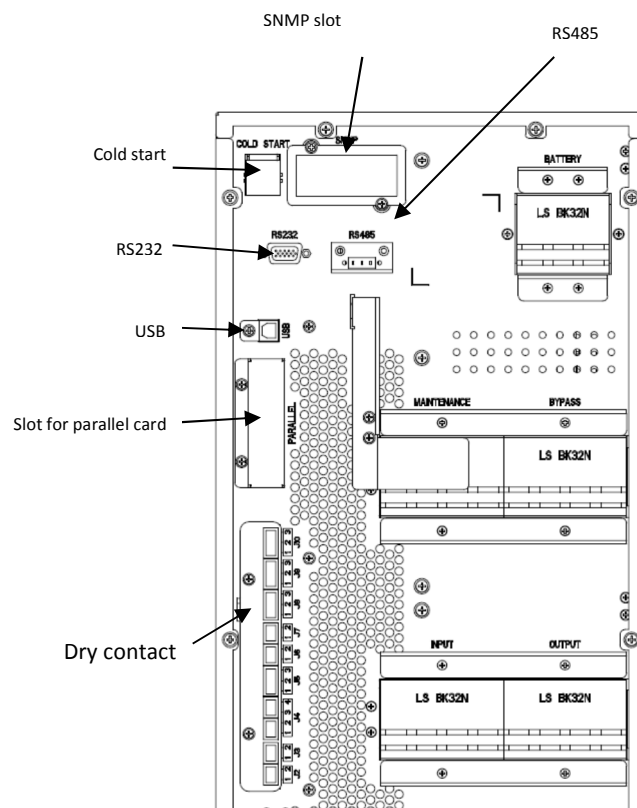

Figure 2-11 Communication interface

The wires connected to the DryContact interface must be potential-free and separate from AC conductors. Wires should be double insulated with a cross section of 0.5-1.5 mm² and their maximum length should not exceed 50m.

2.8.1. Dry Contact - sensor for detecting battery temperature and environment

The Dry Contact J2 and J3 input signals are used to detect the temperature of the battery and the environment at the sensor site. The battery temperature sensor is used to compensate the temperature of the battery charging voltage. The interface and connection description are shown below.

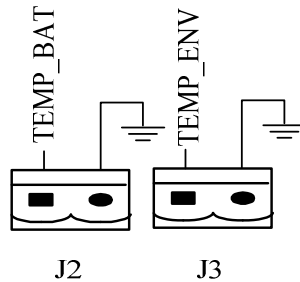

Figure 2-6 View of the interface DryContact J2 and J3

Table 2-2 Description of DryContact J2 and J3 interface terminals

Pin	Description	Purpose
J2.1	TEMP_BAT	Battery temperature detection
J2.2	GND	Ground
J3.1	TEMP_ENV	Environmental temperature detection
J3.2	GND	Ground

Note: Use suitable temperature sensors for proper detection (R25 = 5 Ohm, B25 / 50 = 3275). Please confirm the compliance of the supplier at the time of placing the order.

2.8.2. REPO switch port

The UPS has a REPO interface to remotely shutdown the UPS in case of an emergency (eg fire). The function can be activated by pressing the key on the front panel of the power supply or remotely using the remote REPO switch.

Use the J4 connector to connect the remote REPO. During normal operation, NC and + 24V short-circuits are required. Activation of the EPO signal occurs when the NC signal is + 24V open or short circuit of the NO and + 24V pins. The interface and connection description are shown below.

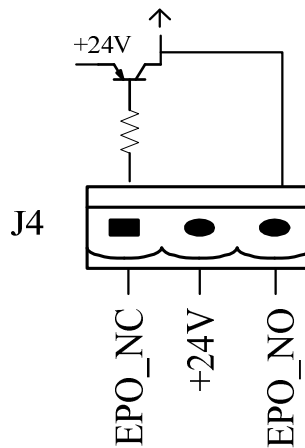

Figure 2-7 Interface REPO

Table 2-3 Description of the REPO interface terminals

Pin	Description	Purpose
J4.1	EPO_NC	EPO is activated when disconnected from J4.2
J4.2	+24V	+24V, voltage to connect with NC and NO
J4.3	EPO_NO	EPO is activated when connecting to J4.2

Use an external potential-free REPO circuit breaker using a normally closed (NC) or normally open (NO) contact.

If you do not use the remote REPO, pin J4.1 must be connected to J4.2 and pin J4.2 disconnected from J4.3.



Warning

1. Using the EPO switch causes the rectifier, inverter, and Bypass to stop, and disconnect the power supply at the output of the power supply.
2. Standard pin J4.1 and J4.2 are connected to each other at the time of delivery.

2.8.3. External bypass interface

Input connector J5 is used for communication with external bypass. Pins J5.1 and J5.2 are open (NO) while the UPS is operating normally (bypass bypass in UPS position). Bypassing the external bypass to the BYPASS position closes the 5.1 and 5.2 (NC) pins.

The UPS automatically returns to normal operation when the bypass is switched to the UPS position.

Table 2-4 Description of interface terminals

Pin	Description	Purpose
J5.1	EXT Bypass	Signaling work bypass external
J5.2	EXT Bypass	Signaling work bypass external
J5.3	n/a	n/a

2.8.4. Interface to BCB battery switch

J6 and J7 connectors are used in conjunction with the optional BCB battery circuit breaker. The interface and connection description are shown below.

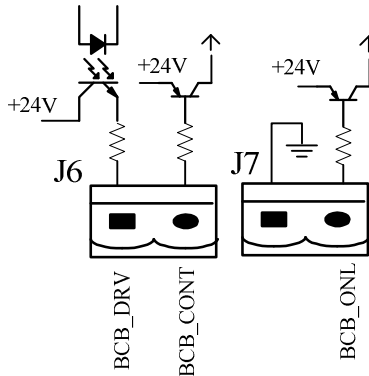

Figure 2-8 Interface BCB

Tabela 2-5 Description of BCB interface

Pin	Description	Purpose
J6.1	BCB_DRV	Output signal for triggering (disconnecting) of the battery disconnector in case of EPO trip or eg deep discharge of battery. Generated + 18V, 20mA signal
J6.2	BCB_CONT	Input signal indicating the position of the battery switch On / Off.
J7.1	GND	Ground
J7.2	BCB_ONL	Input signal indicating the connection to the UPS, BCB. Signal shortage with J7.1 tells UPS to install the BCB.

2.8.5. Output signal - Low battery

The Dry Contact J8 connector is a low battery information. If the battery voltage is lower than the value set, then the J8 output will receive this information. There are two types of battery status signal - NO (normally open contact) or NC (normally closed contact) - change of contact position means low battery voltage. Below the interface description and description of the connection.

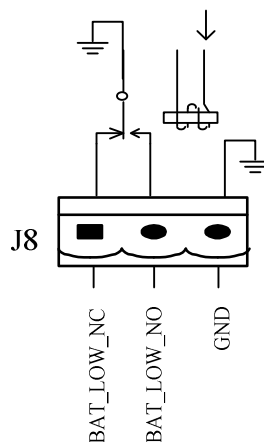

Figure 2-9 Interface Bat_Low

Table 2-6 Description of Bat Low interface terminals

Pin	Description	Purpose
J8.1	BAT_LOW_NC	Relay indicating low battery voltage - normally closed (J8.1 and J8.3). Opening it means a warning about low battery voltage.
J8.2	BAT_LOW_NO	Relay indicating low battery voltage - normally open (J8.2 and J8.3). Its closure means a warning of low battery voltage.
J8.3	GND	Common pin for NO / NC signals.

2.8.6. Output signal - event warning

Connector J9 is a signal that one or more warnings appear on the UPS. Occurrence of at least one alarm on the UPS causes the relay contacts to close or open. Below the interface description and description of the connection.

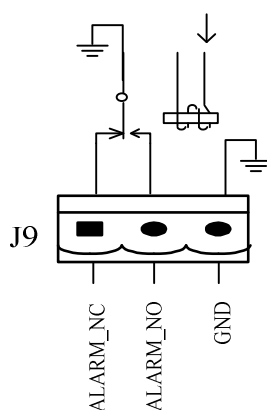

Figure 2-10 Alarm interface

Table 2-7 Description of alarm interface terminals

Pin	Description	Purpose
J9.1	ALARM_NC	Relay indicating the occurrence of an alarm - normally closed (J9.1 and J9.3). Its opening indicates an alarm.
J9.2	ALARM_NO	Alarm relay indicating normally occurring alarm (J9.2 and J9.3). Its closure indicates an alarm.
J9.3	GND	Common pin for NO / NC signals.

2.8.7. Output signal - no power supply

Connector J10 is a signal indicating power failure at the UPS input. Below the interface description and description of the connection.

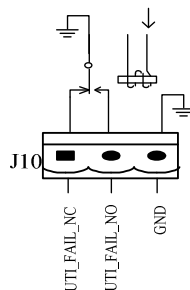

Figure 2-11 Interface for power failure

Table 2-8 Description of the interface power supply interface terminals

Pin	Description	Purpose
J10.1	UTI_FAIL_NC	Relay indicating power failure - normally closed (J10.1 and J10.3). Its opening means the disappearance.
J10.2	UTI_FAIL_NO	Relay indicating power failure - normally open (J10.2 and J10.3). Its closure means the disappearance.
J10.3	GND	Common pin for NO / NC signals

2.8.8. Port USB, RS-232 and RS-485

USB, RS-232 and RS-485 ports are used to communicate the power supply to the monitoring software and to configure the power supply by the manufacturer's authorized service provider.

Pin description for RS-485 socket:

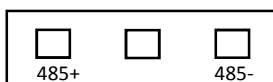

2.8.9. SNMP slot and parallel card slot

The SNMP Slot is used to optionally connect a remote communication card via Web / SNMP.

UPS also allows parallel operation when the UPS is upgraded to a parallel card that is mounted in a special slot designed for mounting this type of card.

3. UPS operating modes

This chapter describes the basic operating modes of the UPS, battery management and protection.

 Warning: There are dangerous voltages - mains and batteries inside the UPS
There are no user serviceable parts inside the UPS. Only the manufacturer's authorized service provider has the opportunity to open the UPS.

3.1. Introduction

The UPS provides the highest reliability for critical equipment. Voltage parameters generated by the power supply are stable and devoid of fluctuations in both voltage and frequency values, and completely independent of voltage parameters in the professional network.

Achieving high quality parameters guarantees high frequency dual pulse width modulation (PWM), all controlled by digital signal processing (DSP), which ensures high reliability and ease of use.

3.2. Principle of operation

As shown in the figure below, the power supply from the professional network feeds the UPS. The rectifier transforms the AC voltage into DC. The constant voltage powers the inverter circuit, which reprograms the DC voltage into a stable AC voltage that is completely independent of the input voltage. In the absence of mains voltage, the inverter circuit is powered by the voltage accumulated in the batteries. In case of maintenance work, or in case of overload, overheat or other events on the UPS, a backup power supply is used - bypass.

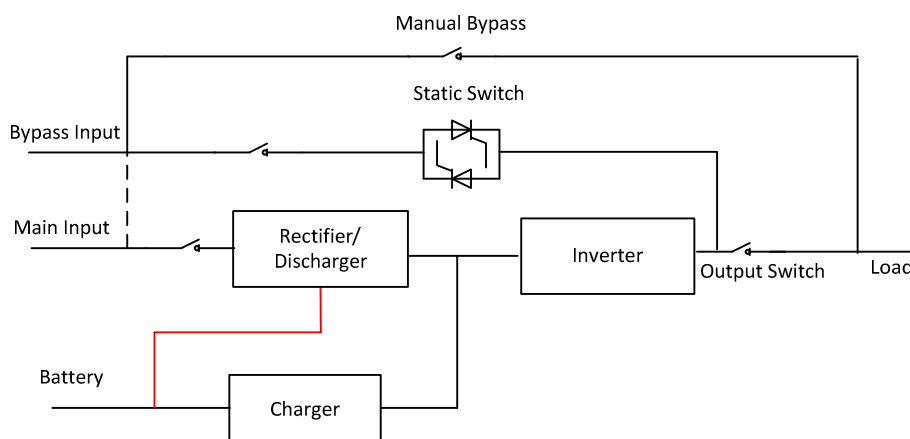



Figure 3-1 Block diagram of the power supply

3.2.1. Bypass module

The Bypass circuit is an electronic uninterruptible switch that supplies voltage to the inverter output or through bypass. During normal operation, the receivers are powered directly from the inverter output, but if events such as overload, overheating or inverter failure occur, the load is automatically switched to the Bypass circuit.

To ensure uninterrupted switching between inverter operation and bypass operation, the inverter output must remain synchronized with the Bypass line voltage at all times. Synchronization is provided by the inverter voltage and frequency control system, which ensures synchronization of the frequency generated by the inverter to the Bypass circuit voltage, provided that the bypass voltage remains within the allowable tolerance range.

The UPS was additionally equipped with a service bypass system. The bypass is manually switched on when maintenance work is required on the UPS. Service bypass can only be activated if the UPS is in Electronic Bypass mode.

 Warning
When the UPS is in Bypass or Service bypass mode, the connected receivers are not protected by power outages and network disruptions.

3.3. Modes of operation of the power supply

The NGS COVER power supply unit is a dual energy processing unit that allows you to operate in the following modes depending on your configuration:

1. Normal mode (On Line)
2. Battery mode
3. Autorestart
4. Electronic bypass
5. Service bypass
6. Economical (ECO)
7. Frequency converter
8. Parallel work (up to 4 units)

1. Normal mode

In normal operation, the output voltage from the UPS is generated by the inverter. Normal operation means that there is a voltage in the professional network with the appropriate parameters that feeds the power supply rectifier. Straight-up voltage is a source of power for the inverter circuit, which produces a guaranteed voltage with stable and fully independent input voltage parameters. In normal operation, rechargeable batteries are also charged.

2. Battery mode

In the event of a power failure in the professional network, the power supply inverter consumes the energy stored in the battery. During power failure in the network, the battery is switched to uninterruptible mode, which means that there is no power interruption from the point of

view of the power supply. Voltage return on the professional network automatically returns to normal mode, without the need to intervene.

Note: The UPS can also be started from the battery in the so-called mode. "Cold start", ie in the absence of basic power.

3. Autorestart

In case of prolonged power failure, when the batteries are discharged after reaching the minimum voltage (EOD - End Of Discharge). The UPS is turned off. The power supply can be configured for automatic restart after a service time delay set by the serviceman. The restart mode and any delay of the inverter can be programmed by the manufacturer's service.

During the programmed delay time of the inverter inverter, the batteries are charged so that when the inverter is turned on, the receivers will be protected in the event of a power failure.

4. Bypass mode

In the case of overload of the power supply, overheating or other causes such as damage to the inverter in normal operation, the bypass switches are automatically and uninterruptedly switched to bypass.

5. Service bypass

The manual service bypass provided by the UPS allows you to carry out periodic maintenance work on the unit without de-energizing the power supply to the receivers. Service Bypass can be activated only when the UPS is in Bypass mode. Therefore, first switch the UPS to Bypass mode and then switch on the service bypass switch.

 Attention	When the UPS is in service bypass mode, the power modules and the LCD display do not work. Please note that there is a dangerous voltage on the terminal strip to which the power supply and the load are connected.
--	--

6. Economical (ECO)

In ECO mode, receivers are powered directly from the network through the Bypass reserve circuit, which improves the efficiency of the power supply and reduces energy consumption. In ECO mode, the preferred source of power is the bypass circuit until the voltage and frequency remain within acceptable tolerances. If the voltage parameters in the Bypass line are outside the set tolerance range, the inverter will automatically switch to the inverter output. Frequency switching is less than 15 ms for 50 Hz and 12.5 ms for 60 Hz.

7. Frequency converter

In the frequency converter mode, the power supply can be used to generate a fixed output frequency of 50 or 60 Hz. The input frequency tolerance range at which a stable output frequency can be generated is 40-70 Hz. Bypass mode is not available in this mode. In the event of power failure, the UPS generates the set frequency using the battery voltage.

4. Power Supply User's Guide

This chapter provides detailed instructions on how to turn the power supply on and off, as well as switching between the modes described in the previous chapters.

All control keys and the LCD panel used to switch between the modes described below are described in detail in Chapter 5.

During the following procedures, acoustic signaling may occur. This alarm can be silenced at any time by pressing "Mute" on the LCD panel.

4.1. Power Switches

The UPS can be switched on or off by means of connectors mounted inside the power supply and accessible when the front door is opened. Below is a look at the power supply with 4 connectors - rectifier input switch, Bypass switch, UPS output switch and Bypass service disconnect switch.

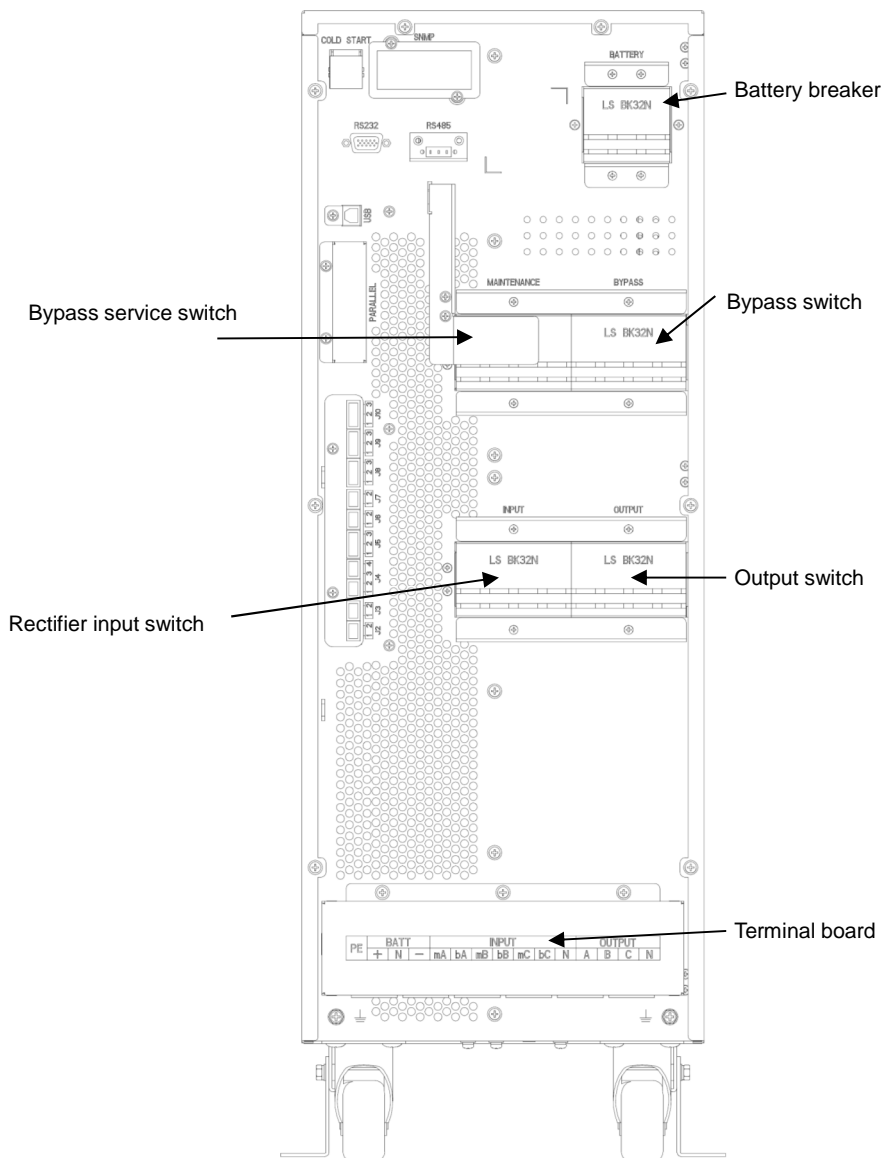

Figure 4-1 Arrangement of power connectors in the power supply in NGS 10-15K

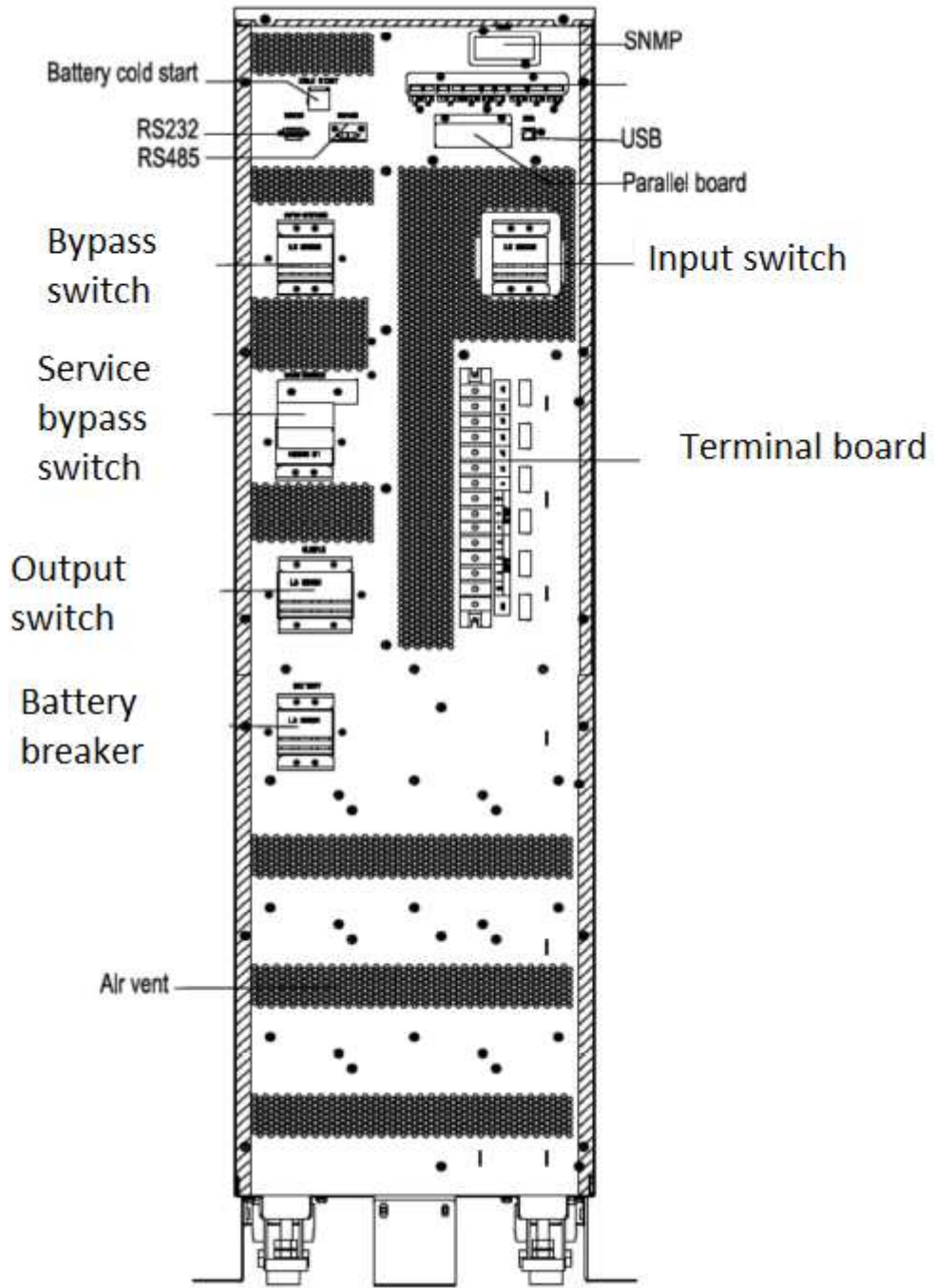

Figure 4-2 Arrangement of power connectors in the power supply in NGS 20-30K

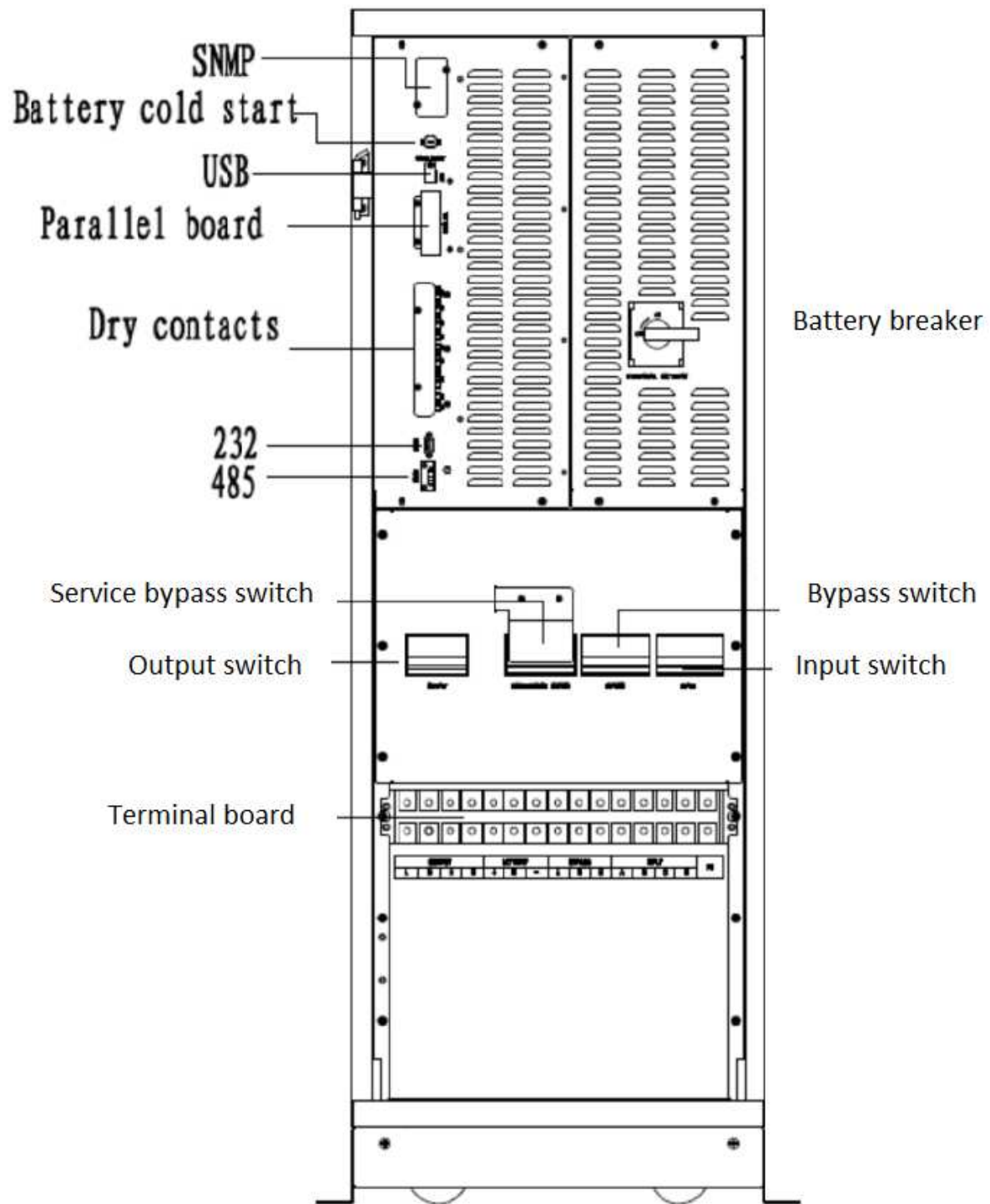



Figure 4-3 Arrangement of power connectors in the power supply in NGS 40K

4.2. Procedures to start the power supply

4.2.1. Start up the UPS from full shutdown

Use the following procedure when starting the power supply from total shutdown.

 Warning	<p>When the following procedure is performed, voltage appears on the output terminals of the power supply. If the power supply is connected to receivers, check that the power supply is safe. If the receivers are not ready to connect the power supply, make sure that they are securely isolated from the UPS output.</p>
--	---

The startup procedure for a dual power supply is as follows:

1. Close the UPS output disconnect switch.
2. Close the bypass input switch and then the rectifier. The order of inclusion is very important.

During commissioning, the LCD is turned on. The rectifier LED flashes during the start up of the rectifier. Running takes about 30 seconds, after which the LED starts to glow green. After the start-up and testing process, Bypass is enabled. The LEDs on the UPS should look like the following table:

LED	State
Rec diode	Green
Battery diode	Red
Bypass diode	Green
Inv diode	Off
Output diode	Green
State diode	Red

When the inverter is switched on, the inverter's LED blinks. When the UPS is fully powered up, the UPS is in bypass mode and then the inverter is switched to the inverter output (normal operation). After switching to the inverter's power supply, the Bypass LED goes out and the inverter's LED goes green as follows:

LED	State
Rec diode	Green
Battery diode	Red
Bypass diode	Off
Inv diode	Green
Output diode	Green
State diode	Red

3. Close the battery switch located at the rear of the UPS or off the UPS, such as on the battery rack. The red battery light goes out. Then the batteries are charged by the UPS.

LED	Status
Rec diode	Green
Battery diode	Green
Bypass diode	Off
Inv diode	Green
Output diode	Green
State diode	Green

UPS is operating in normal mode.

4.2.2. Starting the UPS from the battery (for UPS with "Cold start")

1. Check that the batteries are connected. Close the battery disconnect switch on the back of the UPS or off the UPS when using an external battery.
2. Press the "cold start" button of the power supply located on the back panel of the power supply.

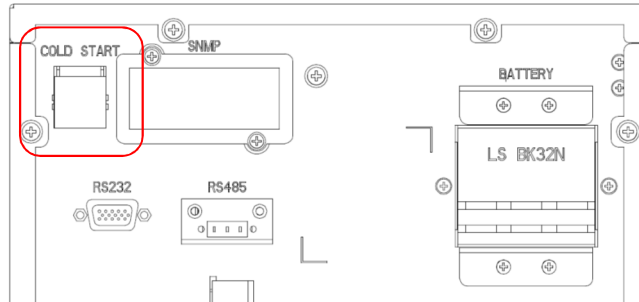

Figure 4-4 Location of the "cold start" button

3. The inverter starts up automatically, the inverter's LED blinks. The power supply is turned off after approximately 60 seconds. The power supply operates in battery mode. The rectifier LED flashes red.

4.3. Procedures for switching the power supply between modes

4.3.1. Switching from normal to battery mode

Open the rectifier power supply disconnect switch to disconnect the UPS. UPS will go into battery mode. If the power supply is to be switched back to normal operation, wait a few seconds and then close the power supply disconnect switch. After approximately 10 seconds, the rectifier is started and the mode is switched to normal mode.

4.3.2. Switching from Normal to Bypass mode

Press the key with the icon  on the LCD panel, then select a command Manual Byp.

 **Warning**

In Bypass mode, the loads are powered directly from the network and are not protected against the effects of power outages and interruptions.

4.3.3. Switching from Bypass mode to normal operation

Press the key with the icon  on the LCD panel, then select a command Manual ESC. UPS will switch from Bypass mode to normal mode (On-Line).

4.3.4. Switching from Normal to Service bypass mode.

The following procedures allow you to switch the UPS from normal to maintenance bypass (Service bypass mode).

 Attention
Before performing the following procedure, ensure that the voltage and frequency parameters in the Bypass line are correct and that the inverter is synchronized to the Bypass voltage. Fulfillment of these conditions guarantees uninterrupted switching of the supply to bypass.

1. Switch UPS to Bypass mode as described in chapter 4.3.2.

Use command Manual Byp the LCD displays the inverter diode and acoustic signaling.

The power supply is in Bypass mode, the UPS inverter is off.

2. Remove the cover of the bypass switch (maintenance switch) and switch the switch to the bypass position. The receivers will be powered by a bypass circuit. Open the rectifier power switch and Bypass, as well as the battery switch located on or off the UPS.

 Attention
If it is necessary to open the power module enclosures, eg during the review, wait at least 10 minutes until the DC capacitors are discharged inside the module.

4.3.5. Switching from Service Bypass mode to normal operation

The following procedure allows you to switch the power supply from bypass (Bypass service) to normal operation.

1. Close the bypass switch and switch the maintenance bypass switch to the UPS position. The Bypass LED lights up in green, the power is fed through the Bypass.
2. Replace the retainer securing the Maintenance bypass switch before accidental use.
3. Close the rectifier input switch.
The power is fed via an electronic bypass. In the meantime the rectifier will start up and after about 30 seconds the rectifier diode should glow green. Then the power supply inverter will automatically start - it may take about 1 minute.
4. Close the battery disconnect switch located on or off the UPS. The battery light goes out.

4.4. Complete power off procedure

To completely disconnect the UPS and powered receivers, proceed to step 4.3.4 of the Bypass service and then disconnect the UPS from the power distribution board.

4.5. Emergency shutdown with EPO

The UPS Emergency Power Button is located on the front panel of the UPS and is used for emergency shutdown in the event of a flood, fire, etc. The EPO circuit breaker immediately extinguishes the rectifier, inverter and disconnects the UPS output and stops charging or discharging the battery.

In order to start the UPS for normal operation after EPO use, restore the emergency stop to its normal position, supply voltage to the UPS and carry out the power supply startup procedure from the off state. To do so, reset the position of the disconnectors to the OFF position and follow the procedure in 4.2.1.

5. Operation of the LCD panel

The following section describes the functions and capabilities of the control panel in the power supply, including key functions and available information from the LCD touch screen.

5.1. Introduction

The power supply panel with LCD display is located on the front panel of the UPS. The LCD display gives the user full access to work status monitoring, switching between operating modes as well as control of work parameters and event logging. The power supply control panel is divided into three sections, as shown in the figure below. On the left there is a keypad with EPO switch, LED energy flow display and LCD display. The symbol details shown on the LCD panel are explained in the table below.

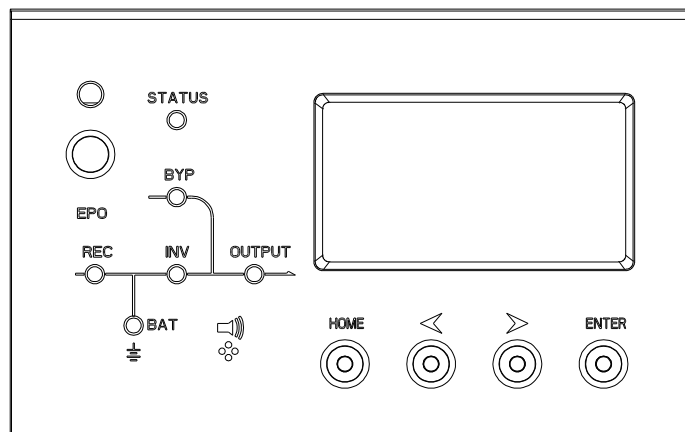

Figure 5-1 View of the power supply control panel

Table 5-1 Description of the symbols used on the power supply control panel

Symbol	Function	Key	Function
REC	Rec diode	EPO	Emergency power off
BAT	Battery diode	HOME	Back to main menu
BYP	Bypass diode	Arrows left - right	Crossing lines, changing parameters
INV	Inv diode	ENTER	Confirm
OUTPUT	Load diode		
STATUS	State diode		

5.1.1. LED indicators

The LED energy flow diagram shows the current status of the power supply, the power flow in the UPS, and the state of the individual UPS components. Detailed description of each diode below.

Table 5-2 A description of the meaning of each state of the LED indicator

Indicator	State	Description
Rec diode	Green	Rectifier OK
	Green flashing	The rectifier starts up, the power supply is normal
	Red	Damage to the rectifier
	Red flashing	Power off the norm
	None	Recitifier off
Battery diode	Green	Charging batteries
	Green flashing	Discharging batteries
	Red	Incorrect battery status (battery failure, no batteries attached or reverse polarity) or DC / DC converter (damage, overload or overheat), EOD (battery cut off voltage).
	Red flashing	Low voltage of the battery
	None	Batteries and converter OK, batteries are not charged
Bypass diode	Green	Power feeds from the Bypass track.
	Red	Power Bypass beyond standard or static-switch failure.
	Red flashing	Bypass voltage is invalid
	None	Bypass OK
Inv diode	Green	Power supply from the inverter
	Green flashing	Switch on the inverter, turn it on, sync
	Red	Receivers are not powered from the inverter, the inverter module is faulty
	Red flashing	At least one inverter inverter is faulty
	None	Inverter off
Load diode	Green	The UPS output is switched on and working properly
	Red	Prolonged overload of the power supply, short circuit at the output or no power at the output.
	Red flashing	Overload
	None	No supply at the output
State diode	Green	Normal work
	Red	Failure

5.1.2. Audible alarm

There are two types of acoustic signaling in the UPS. Both are described in the table below.

Alarm	Description
Two short alarms and one long one	Appears at events such as No Power.
Continuous alarm	It appears when a power supply fault occurs, such as a fuse or other component failure.

5.1.3. Function keys

There are 4 keys on the power board. The meaning of the keys is described below.

Key	Function
EPO switch	Emergency power switch off.
HOME	Switching between functions.
ENTER	Confirmation
Arrows Left/Right	Choosing menu options, changing a parameter, navigating between menu lines

5.2. LCD screen

After self-diagnosis, the UPS touch screen should look like the figure below.

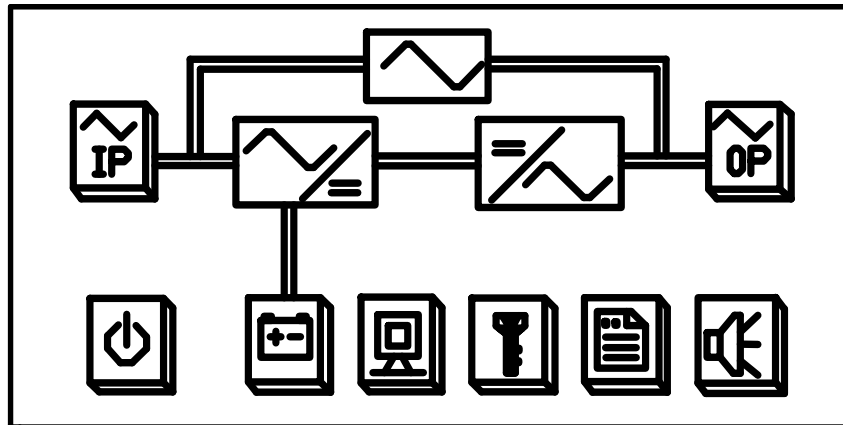















Figure 5-2 LCD screen

Icon	Description
	Turn on/off
	Input parameters for rectifier and bypass
	Event history
	UPS Features, System Configuration (service only)
	Battery parameters, battery configuration (service only)
	Battery test
	Service Operations (Fault Clear, History-log Clear, Mute, Manual Transfer, Service Settings, System ID, Output Adjustment, Slew Rate, Synchronize Window)
	Output and load parameters
	State
	Mute
	Scroll up / down page





Choosing icon  displays the UPS battery parameters.

HOME  BATTERY P.1  NEXT	
Batt Volt	240.0 V 240.0 V
Batt Curr	5.0 A 5.0 A
Batt Number	40
Dischag Times	10
Status	Batt Boost



Choosing icon  displays the UPS power parameters.

HOME  I/P MAIN  NEXT		
A	B	C
220.1 V	220.1 V	220.1 V
45.0 A	45.0 A	45.0 A
50.01 Hz	50.01 Hz	50.01 Hz
0.99 PF	0.99 PF	0.99 PF

Choosing , indicates the current UPS status;

Choosing , mutes the alarm generated by the UPS;

Choosing , indicates information and UPS event codes.

5.2.1. System information

The UPS information window indicates the UPS model and the current time.

Indication	Description
3315S	UPS: 3-phase input, 3-phase output power 15kVA, UPS with standard charger
16:30	Current time

5.3. Detailed list of information available on the LCD panel

Table 5-3 Description of the available parameters in the data window

Menu	Overlap	Description
Main input	V phase(V)	Voltage
	I phase(A)	Current
	Freq.(Hz)	Frequency
	PF	Power factor
Bypass input	V phase(V)	Voltage
	Freq. (Hz)	Current
	I phase(A)	Frequency
	PF	Power factor
Output	V phase(V)	Voltage
	I phase(A)	Current
	Freq. (Hz)	Frequency
	PF	Power factor
This UPS module's load	Sout (kVA)	Apparent power
	Pout (kW)	Active power
	Qout (kVAR)	Reactive power
	Load (%)	Percentage load
Battery data	Environmental Temp	Ambient temperature
	Battery voltage(V)	Voltage of positive and negative battery half
	Battery current A)	Current positive and negative battery half
	Battery Temp(°C)	Battery temperature
	Remaining Time (Min.)	Remaining battery life
	Battery capacity (%)	Remaining battery capacity
	battery boost charging	Charging the battery in Boost mode
	battery float charging	Charging the battery in Float mode
	Battery disconnected	Batteries not connected

Menu	Overlap	Description
Current alarm		Displays all active alerts
History log		Displays all available UPS event history.
Function Settings	Display calibration	Calibrate the contrast of the LCD display
	Date format set	Select how Month-Day-Year-or Year-Month-Day will be displayed
	Date & Time	Setting date and time
	Language set	Language setting
	Communication set	/
	Control password 1 set	Modify level 1 password.
Command	Battery maintenance test	Force the battery test to continue until the cut off voltage is reached. The bypass must be available and the battery charge level must be greater than 25%.
	Battery self-check test	Force battery to check battery condition. Bypass must be available and the battery charge level must be greater than 25%.
	Stop testing	End of battery test.
UPS system information	Monitoring software version	UPS monitoring software version
	Rectified software version	Rectifier software version
	Inverted software version	Software version of the inverter
	Serial No.	Serial number of the UPS
	Rated information	UPS power information
	Module model	UPS power information

5.4. List of events and alarm

Below is a list of all available alarms and events that can be displayed on the UPS.

<i>String Sequence</i>	<i>LCD screen</i>	<i>Description</i>
1	<i>Load On UPS-Set</i>	<i>Work with inverter</i>
2	<i>Load On Bypass-Set</i>	<i>Work bypass</i>
3	<i>No Load-Set</i>	<i>No output voltage</i>
4	<i>Battery Boost-Set</i>	<i>Charger in Boost mode</i>
5	<i>Battery Float-Set</i>	<i>Charger in Float mode</i>
6	<i>Battery Discharge-Set</i>	<i>Discharging the battery</i>
7	<i>Battery Connected-Set</i>	<i>Battery connected</i>
8	<i>Battery Not Connected-Set</i>	<i>Battery disconnected</i>
9	<i>Maintenance CB Closed-Set</i>	<i>Service bypass switch closed</i>
10	<i>Maintenance CB Open-Set</i>	<i>Service bypass switch open</i>
11	<i>EPO-Set</i>	<i>Emergency shutdown with EPO</i>
12	<i>Module On Less-Set</i>	<i>Inverter module power is lower than load</i>
13	<i>Module On Less-Clear</i>	<i>End of the above message</i>
14	<i>Generator Input-Set</i>	<i>Working with the aggregate</i>
15	<i>Generator Input-Clear</i>	<i>End of the above message</i>
16	<i>Utility Abnormal-Set</i>	<i>Power is incorrect</i>
17	<i>Utility Abnormal-Clear</i>	<i>End of the above message</i>
18	<i>Bypass Sequence Error-Set</i>	<i>Sequence of bypass power phases incorrect</i>
19	<i>Bypass Sequence Error-Clear</i>	<i>End of the above message</i>
20	<i>Bypass Volt Abnormal-Set</i>	<i>Incorrect voltage bypass</i>
21	<i>Bypass Volt Abnormal-Clear</i>	<i>End of the above message</i>
22	<i>Bypass Module Fail-Set</i>	<i>Damaged bypass module</i>
23	<i>Bypass Module Fail-Clear</i>	<i>End of the above message</i>

24	<i>Bypass Overload-Set</i>	<i>Overload bypass</i>
25	<i>Bypass Overload-Clear</i>	<i>End of the above message</i>
26	<i>Bypass Overload Tout-Set</i>	<i>Overload bypass</i>
27	<i>Byp Overload Tout-Clear</i>	<i>End of the above message</i>
28	<i>Byp Freq Over Track-Set</i>	<i>Frequency bypass out of range</i>
29	<i>Byp Freq Over Track-Clear</i>	<i>End of the above message</i>
30	<i>Exceed Tx Times Lmt-Set</i>	<i>Switching time (from inverter to bypass) in the last hour exceeded the limit.</i>
31	<i>Exceed Tx Times Lmt-Clear</i>	<i>End of the above message</i>
32	<i>Output Short Circuit-Set</i>	<i>Short circuit output</i>
33	<i>Output Short Circuit-Clear</i>	<i>End of the above message</i>
34	<i>Battery EOD-Set</i>	<i>Batteries unloaded</i>
35	<i>Battery EOD-Clear</i>	<i>End of the above message</i>
36	<i>Battery Test-Set</i>	<i>Start the battery test</i>
37	<i>Battery Test OK-Set</i>	<i>Battery test OK</i>
38	<i>Battery Test Fail-Set</i>	<i>Battery test incorrect</i>
39	<i>Battery Maintenance-Set</i>	<i>Start the battery test</i>
40	<i>Batt Maintenance OK-Set</i>	<i>Battery test OK</i>
41	<i>Batt Maintenance Fail-Set</i>	<i>Battery test incorrect</i>
42	<i>Module Inserted-Set</i>	<i>N # power module included</i>
43	<i>Module Exit-Set</i>	<i>N # power module disconnected</i>
44	<i>Rectifier Fail-Set</i>	<i>N # rectifier in faulty module</i>
45	<i>Rectifier Fail-Clear</i>	<i>End of the above message</i>
46	<i>Inverter Fail-Set</i>	<i>Inverter failure</i>
47	<i>Inverter Fail-Clear</i>	<i>End of the above message</i>
48	<i>Rectifier Over Temp.-Set</i>	<i>Too high rectifier temperature</i>
49	<i>Rectifier Over Temp.-Clear</i>	<i>End of the above message</i>
50	<i>Fan Fail-Set</i>	<i>Fan failure</i>
51	<i>Fan Fail-Clear</i>	<i>End of the above message</i>

52	<i>Output Overload-Set</i>	<i>Overload of the power supply</i>
53	<i>Output Overload-Clear</i>	<i>End of the above message</i>
54	<i>Inverter Overload Tout-Set</i>	<i>N # power module overload time has expired</i>
55	<i>INV Overload Tout-Clear</i>	<i>End of the above message</i>
56	<i>Inverter Over Temp.-Set</i>	<i>N# moduł mocy przegrzany</i>
57	<i>Inverter Over Temp.-Clear</i>	<i>End of the above message</i>
58	<i>On UPS Inhibited-Set</i>	<i>Unauthorized switching from bypass to inverter</i>
59	<i>On UPS Inhibited-Clear</i>	<i>End of the above message</i>
60	<i>Manual Transfer Byp-Set</i>	<i>Manually toggle to bypass</i>
61	<i>Manual Transfer Byp-Set</i>	<i>Cancel the above procedure</i>
62	<i>Esc Manual Bypass-Set</i>	<i>Manual turn on the bypass</i>
63	<i>Battery Volt Low-Set</i>	<i>Low battery voltage</i>
64	<i>Battery Volt Low-Clear</i>	<i>End of the above message</i>
65	<i>Battery Reverse-Set</i>	<i>Replace battery polarity</i>
66	<i>Battery Reverse-Clear</i>	<i>End of the above message</i>
67	<i>Inverter Protect-Set</i>	<i>N # protection of the inverter in the power module (incorrect output voltage or feedback voltage)</i>
68	<i>Inverter Protect-Clear</i>	<i>End of the above message</i>
69	<i>Input Neutral Lost-Set</i>	<i>No neutral wire</i>
70	<i>Bypass Fan Fail-Set</i>	<i>The bypass fan is faulty</i>
71	<i>Bypass Fan Fail-Clear</i>	<i>End of the above message</i>
72	<i>Manual Shutdown-Set</i>	<i>N # power module disabled manually</i>
73	<i>Manual Boost Charge-Set</i>	<i>Manual turn on for boost charging</i>
74	<i>Manual Float Charge-Set</i>	<i>Manual turn on for float charging</i>
75	<i>UPS Locked-Set</i>	<i>UPS shutdown blocked</i>
76	<i>Parallel Cable Error-Set</i>	<i>Error connecting parallel work wires</i>
77	<i>Parallel Cable Error-Clear</i>	<i>End of the above message</i>
78	<i>Lost N+X Redundant</i>	<i>Loss of N + X redundancy</i>
79	<i>N+X Redundant Lost-Clear</i>	<i>End of the above message</i>

80	<i>EOD Sys Inhibited</i>	<i>Unable to power on after the battery is discharged</i>
81	<i>Power Share Fail-Set</i>	<i>Uneven distribution of power</i>
82	<i>Power Share Fail-Clear</i>	<i>End of the above message</i>
83	<i>Input Volt Detect Fail-Set</i>	<i>Supply voltage outside the norm</i>
84	<i>Input Volt Detect Fail-Clear</i>	<i>End of the above message</i>
85	<i>Battery Volt Detect Fail-Set</i>	<i>Battery voltage outside normal</i>
86	<i>Batt Volt Detect Fail-Clear</i>	<i>End of the above message</i>
87	<i>Output Volt Fail-Set</i>	<i>Output voltage outside normal</i>
88	<i>Output Volt Fail-Clear</i>	<i>End of the above message</i>
89	<i>Outlet Temp. Error-Set</i>	<i>Socket temperature outside the norm</i>
90	<i>Outlet Temp. Error-Clear</i>	<i>End of the above message</i>
91	<i>Input Curr Unbalance-Set</i>	<i>Input current not evenly distributed</i>
92	<i>Input Curr Unbalance-Clear</i>	<i>End of the above message</i>
93	<i>DC Bus Over Volt-Set</i>	<i>High DC bus voltage</i>
94	<i>DC Bus Over Volt-Clear</i>	<i>End of the above message</i>
95	<i>REC Soft Start Fail-Set</i>	<i>Error rectifier soft start</i>
96	<i>REC Soft Start Fail-Clear</i>	<i>End of the above message</i>
97	<i>Relay Connect Fail-Set</i>	<i>Relay circuit open</i>
98	<i>Relay Connect Fail-Clear</i>	<i>End of the above message</i>
99	<i>Relay Short Circuit-Set</i>	<i>Relay shorted</i>
100	<i>Relay Short Circuit-Clear</i>	<i>End of the above message</i>
101	<i>No Inlet Temp. Sensor-Set</i>	<i>Inlet temperature sensor not connected or damaged</i>
102	<i>No Inlet Temp Sensor-Clear</i>	<i>End of the above message</i>
103	<i>No Outlet Temp. Sensor-Set</i>	<i>Air outlet temperature sensor not connected or damaged</i>
104	<i>No Outlet TmpSensor-Clear</i>	<i>End of the above message</i>
105	<i>Inlet Over Temp.-Set</i>	<i>Too high air temperature at the inlet of the ventilation system</i>
106	<i>Inlet Over Temp.-Clear</i>	<i>End of the above message</i>